

EE105 Lab Experiments

Prelab 10: Differential Amplifiers

Solutions

For this lab, assume all NPN transistors are identical 2N3904 BJTs and all PNP transistors are identical 2N3906 BJTs.

Component	I_S (A)	V_A (V)
2N3904 NPN BJT	6.734×10^{-15}	74.03
2N3906 PNP BJT	1.41×10^{-15}	18.7

Table 1: Transistor properties

A differential pair with a resistive load is shown in Figure 1. Use this circuit to answer the following questions. You can ignore base currents. Use the device parameters given in Table 1. Assume $V_{CC} = 9$ V. Assume that the inputs are biased at 0 V DC.

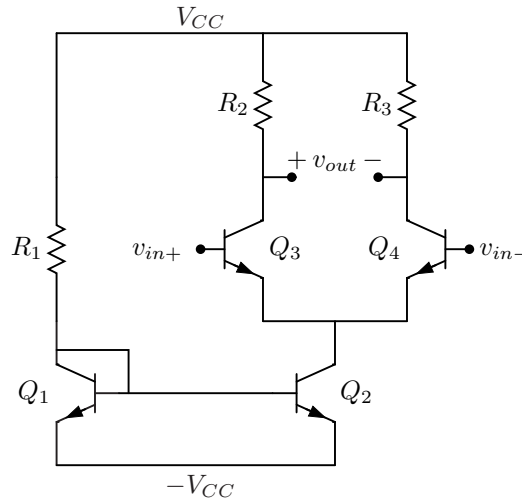

Figure 1: Differential pair with resistive load

1. What value of R_1 would give $I_{C1} = 2$ mA?

$$I_{C1} = 2 \times 10^{-3} = \frac{2V_{CC} - V_{BE1}}{R_1} = I_S e^{V_{BE1}/V_T} \left(1 + \frac{V_{BE1}}{V_A} \right)$$

$$V_{BE1} = 0.6886 \text{ V}$$

$$R_1 = \boxed{8.657 \text{ k}\Omega}$$

2. In lab, we have 500 Ω , 1 k Ω , 5.1 k Ω , and 10 k Ω resistors. Assuming we only wanted to use one resistor for R_1 , which value would give us I_{C1} closest to 2 mA? What current would we get with the resistor you chose? Use this value for R_1 for the remainder of the prelab.

$$R_1 = 10 \text{ k}\Omega$$

$$I_{C1} = \frac{2V_{CC} - V_{BE1}}{R_1} = I_S e^{V_{BE1}/V_T} \left(1 + \frac{V_{BE1}}{V_A} \right)$$

$$V_{BE1} = 0.6866 \text{ V}$$

$$I_{C1} = 1.731 \text{ mA}$$

3. We'd like to bias the common-mode output half-way between 0 V and 9 V to achieve the maximum swing by picking R_2 and R_3 appropriately. Calculate a value for R_2 and R_3 that achieves an output bias of 4.5 V (assuming R_1 is what you chose for the previous question). Out of the resistors listed previously, which should we use? What output bias does it achieve? Use this value (of the available resistors) for R_2 and R_3 for the remainder of the prelab.

$$I_{C3}R_2 = 4.5$$

$$\text{(Exact) } R_2 = R_3 = 5.198 \text{ k}\Omega$$

$$\text{(Available) } R_2 = R_3 = 5 \text{ k}\Omega$$

$$v_{out,DC} = 4.328 \text{ V}$$

4. What is the output resistance of the circuit (be sure to include r_o of the BJTs)? Assume R_2 and R_3 are as you chose them in the previous question (of the available resistors).

$$r_{o4} = \frac{V_{AN}}{I_{C4}} = 85.52 \text{ k}\Omega$$

$$R_{out} = 2r_{o4} \parallel R_3 = 9.448 \text{ k}\Omega$$

Note that since we're taking a differential output, the output resistance is double what you'd get for a single-ended output.

5. What is the differential-mode gain of the circuit?

$$A_{DM} = -g_{m3}R_{out}$$

$$g_{m3} = \frac{I_{C3}}{V_T}$$

$$= 33.30 \text{ mS}$$

$$A_{DM} = -157.28$$

6. What is the common-mode gain of the circuit?

$$A_{CM} = \frac{g_{m3}R_3}{2g_{m3}r_{o2} + 1}$$
$$r_{o2} = 42.76 \text{ k}\Omega$$
$$g_{m3} = 33.30 \text{ mS}$$
$$A_{CM} = \boxed{0.05845}$$

7. What is the common-mode rejection ratio of the circuit? Use $CMRR = \left| \frac{A_{DM}}{A_{CM}} \right|$ rather than the book's equation.

$$CMRR = 2691 = \boxed{68.60 \text{ dB}} \text{ (note the LM741 has a CMRR of 90 dB)}$$