



EECS 373

Design of Microprocessor-Based Systems

Prabal Dutta
University of Michigan

Lecture 11: Sampling, ADCs, and DACs
Oct 7, 2014

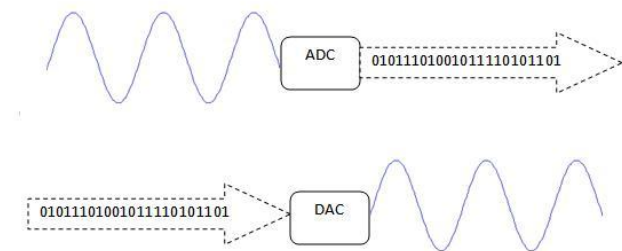
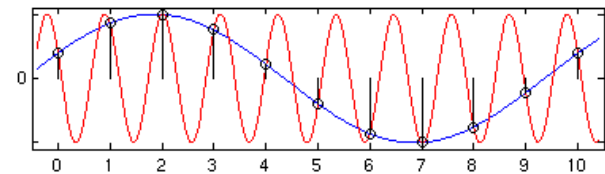

Some slides adapted from Mark Brehob, Jonathan Hui & Steve Reinhardt

Outline



- Announcements
- Sampling
- ADC
- DAC

Announcements



- Exam is a 9 days from today
 - Q&A session on Thursday (10/9) during class
 - Additional Q&A sessions?
 - One page, front and back “cheat sheet”
 - Practice exam
- Special Projects Groups
 - 41 signed up
 - 5 missing → sign up today by midnight or receive a zero
- Group Projects
 - Find group members
 - Brainstorm project ideas!
 - Research projects: let me know ASAP

We live in an analog world



- Everything in the physical world is an analog signal
 - Sound, light, temperature, pressure
- Need to convert into electrical signals
 - Transducers: converts one type of energy to another
 - Electro-mechanical, Photonic, Electrical, ...
 - Examples
 - Microphone/speaker
 - Thermocouples
 - Accelerometers

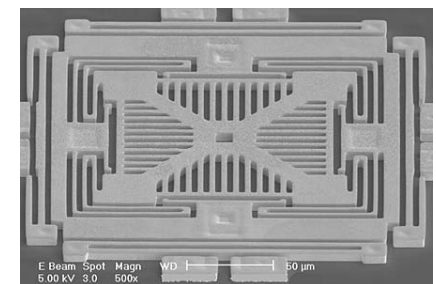
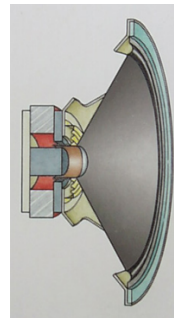



Transducers convert one form of energy into another

- Transducers
 - Allow us to convert physical phenomena to a voltage potential in a well-defined way.

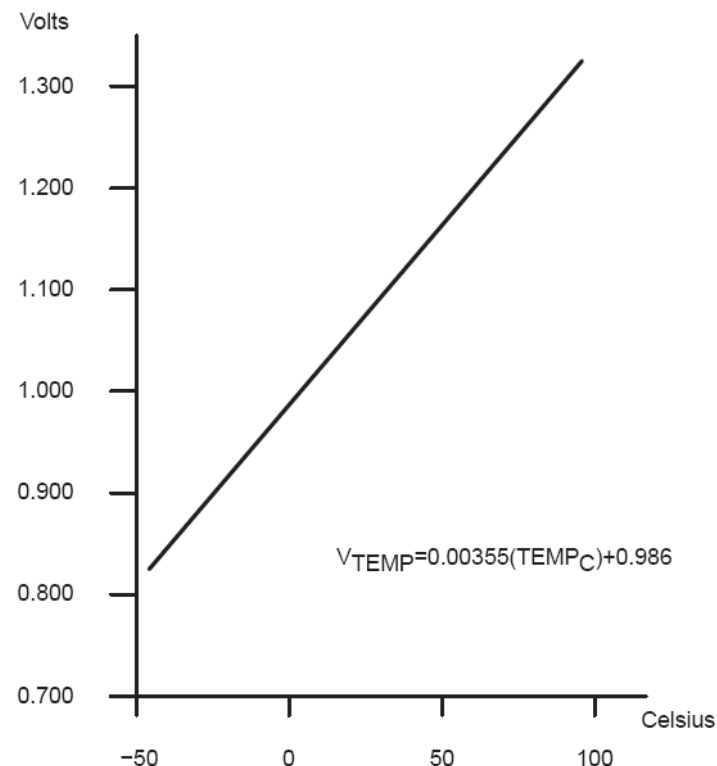

A transducer is a device that converts one type of energy to another. The conversion can be to/from electrical, electro-mechanical, electromagnetic, photonic, photovoltaic, or any other form of energy. While the term transducer commonly implies use as a sensor/detector, any device which converts energy can be considered a transducer. – [Wikipedia](#).

Convert light to voltage with a CdS photocell



$$V_{\text{signal}} = (+5V) R_R / (R + R_R)$$

- Choose $R=R_R$ at median of intended range
- Cadmium Sulfide (CdS)
- Cheap, low current
- $t_{RC} = (R+R_R)*C_l$
 - Typically $R \sim 50\text{-}200\text{k}\Omega$
 - $C \sim 20\text{pF}$
 - So, $t_{RC} \sim 20\text{-}80\mu\text{s}$
 - $f_{RC} \sim 10\text{-}50\text{kHz}$

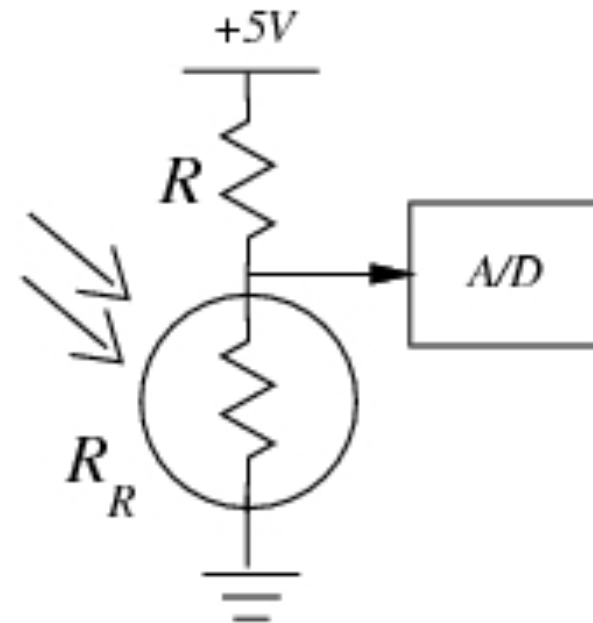

Source: Forrest Brewer

Many other common sensors (some digital)



- Force
 - strain gauges - foil, conductive ink
 - conductive rubber
 - rheostatic fluids
 - Piezoresistive (needs bridge)
 - piezoelectric films
 - capacitive force
 - Charge source
- Sound
 - Microphones
 - Both current and charge versions
 - Sonar
 - Usually Piezoelectric
- Position
 - microswitches
 - shaft encoders
 - gyros
- Acceleration
 - MEMS
 - Pendulum
- Monitoring
 - Battery-level
 - voltage
 - Motor current
 - Stall/velocity
 - Temperature
 - Voltage/Current Source
- Field
 - Antenna
 - Magnetic
 - Hall effect
 - Flux Gate
- Location
 - Permittivity
 - Dielectric

Source: Forrest Brewer



Going from analog to digital

- What we want



- How we have to get there

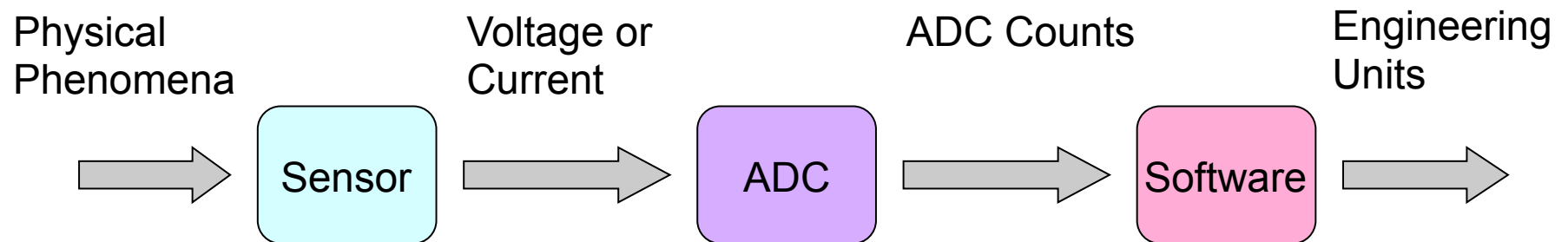

Representing an analog signal digitally



- How do we represent an analog signal?
 - As a time series of discrete values
 - On MCU: read the ADC data register periodically

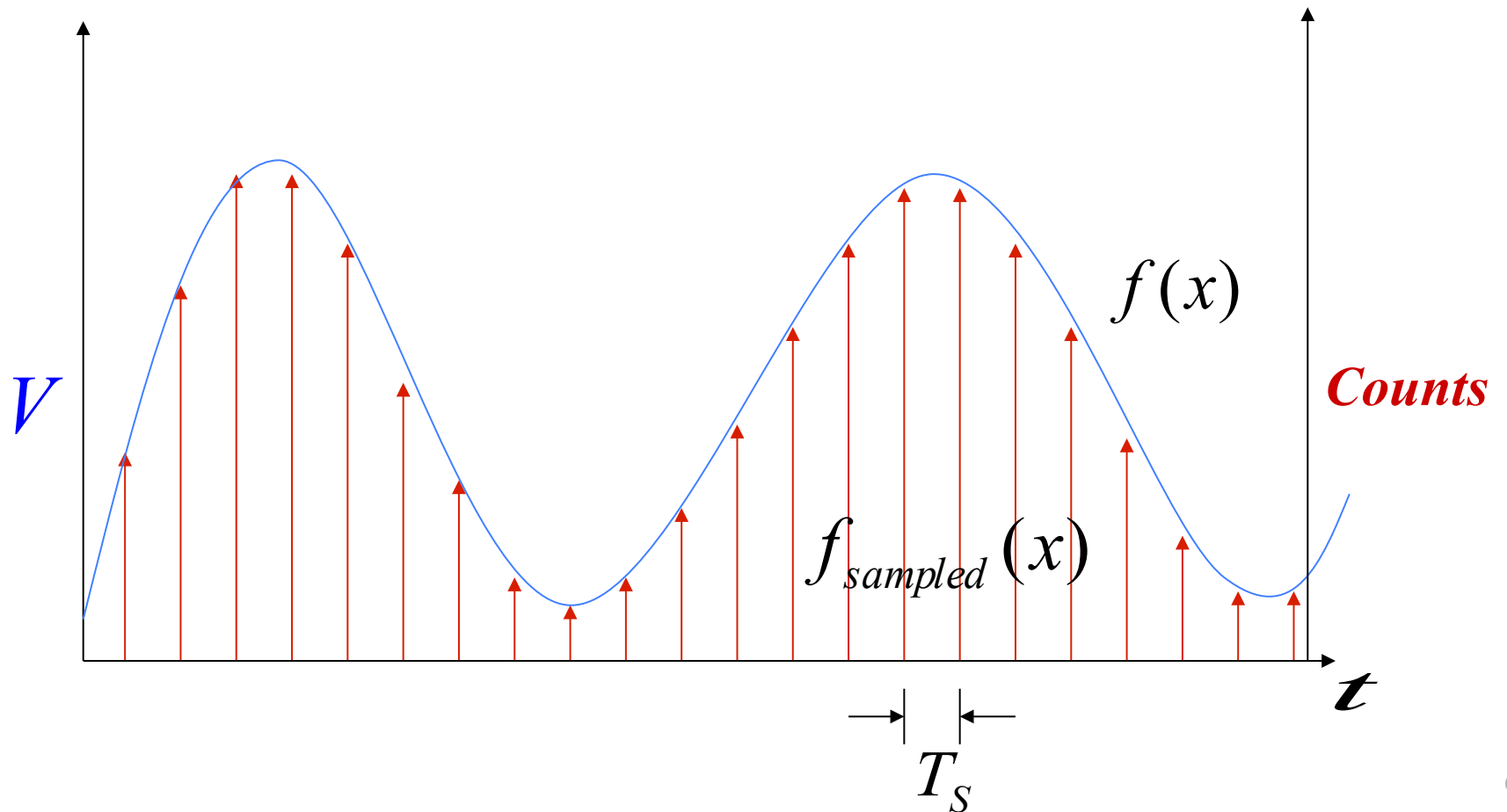

Choosing the horizontal range

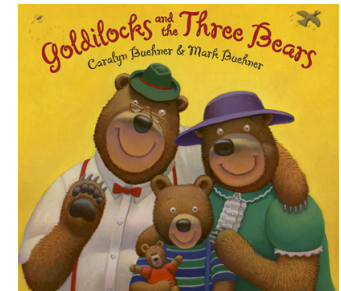

- What do the sample values represent?
 - Some fraction within the range of values

→ *What range to use?*

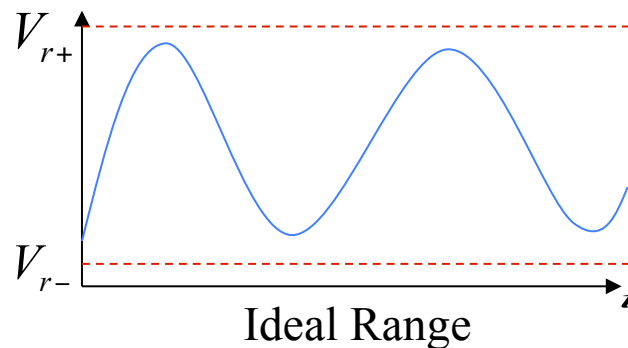
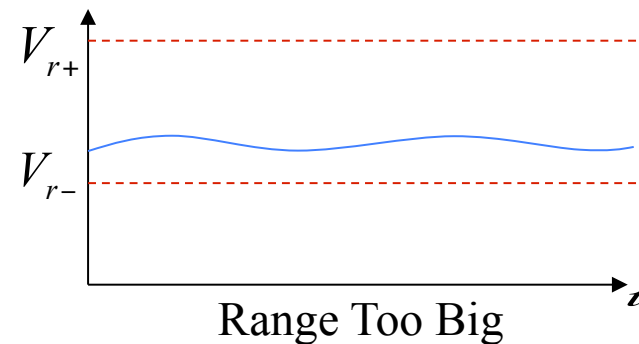
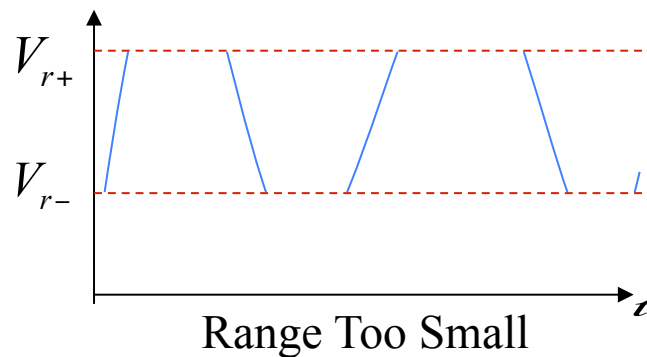

Choosing the horizontal granularity



- Resolution
 - Number of discrete values that represent a range of analog values
 - MSP430: 12-bit ADC
 - 4096 values
 - $\text{Range} / 4096 = \text{Step}$

Larger range → less information

- Quantization Error
 - How far off discrete value is from actual
 - $\frac{1}{2} \text{ LSB} \rightarrow \text{Range} / 8192$

Larger range → larger error

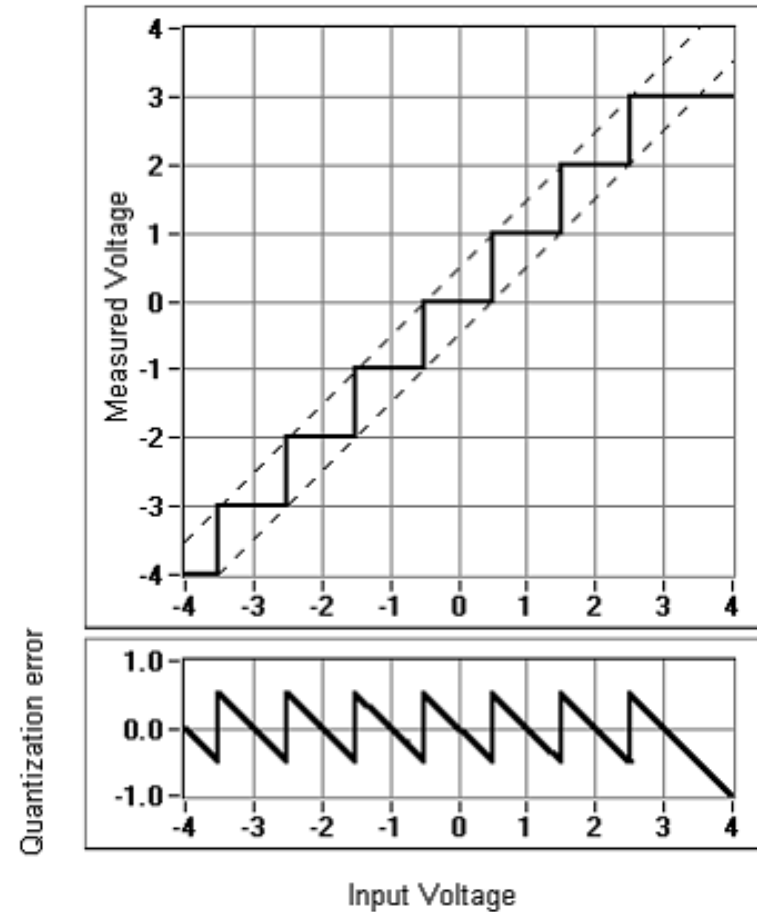

Choosing the sample rate



- What sample rate do we need?
 - Too little: we can't reconstruct the signal we care about
 - Too much: waste computation, energy, resources

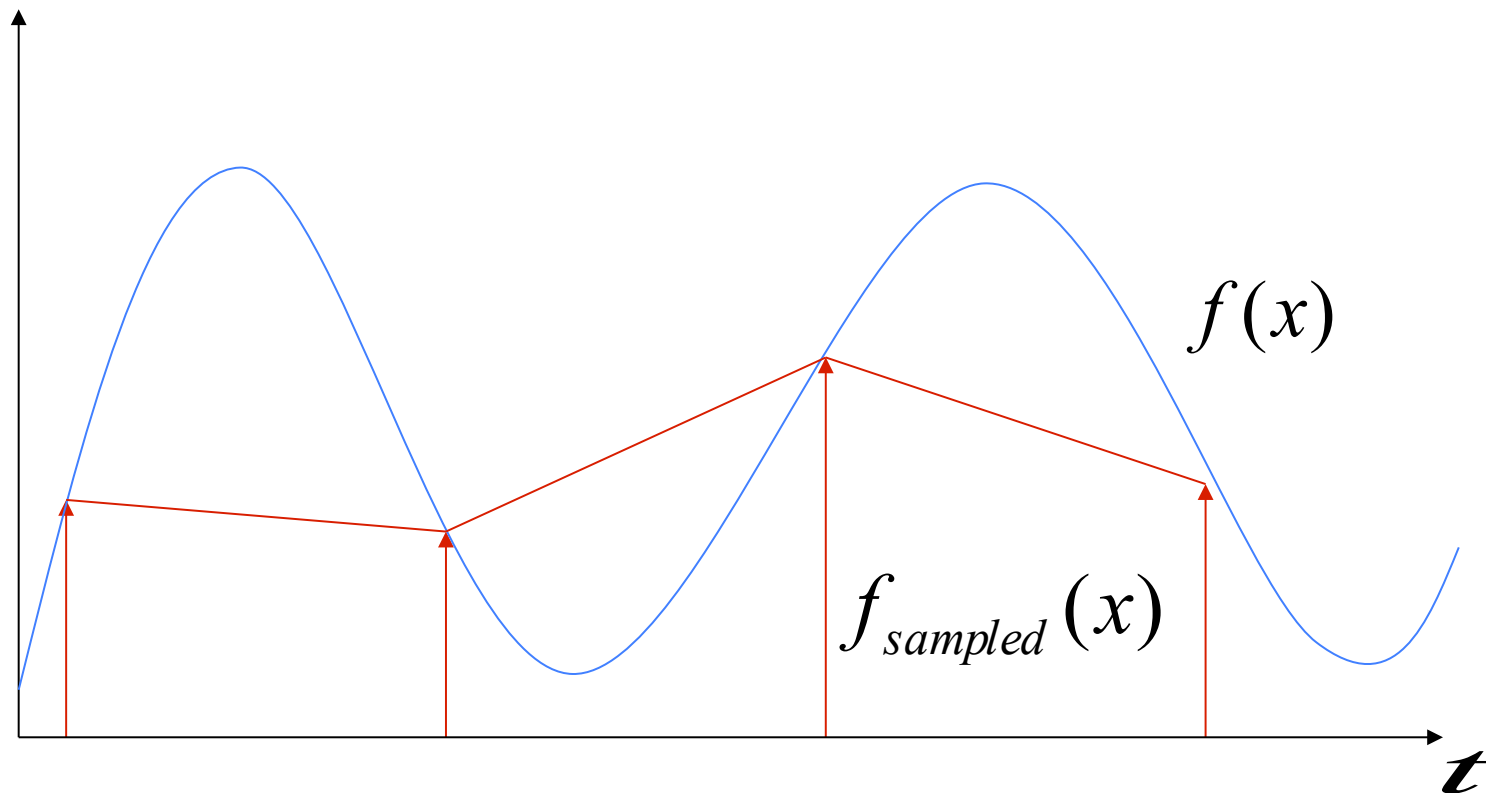

Shannon-Nyquist sampling theorem



- *If a continuous-time signal $f(x)$ contains no frequencies higher than f_{\max} , it can be completely determined by discrete samples taken at a rate:*

$$f_{\text{samples}} > 2f_{\max}$$

- Example:
 - Humans can process audio signals 20 Hz - 20 KHz
 - Audio CDs: sampled at 44.1 KHz



Converting between voltages, ADC counts, and engineering units

- Converting: ADC counts \Leftrightarrow Voltage

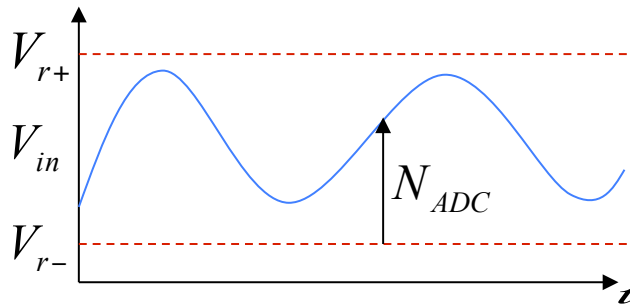

$$N_{ADC} = 4095 \times \frac{V_{in} - V_{R-}}{V_{R+} - V_{R-}}$$
$$V_{in} = N_{ADC} \times \frac{V_{R+} - V_{R-}}{4095}$$

- Converting: Voltage \Leftrightarrow Engineering Units

$$V_{TEMP} = 0.00355(\text{TEMP}_C) + 0.986$$
$$\text{TEMP}_C = \frac{V_{TEMP} - 0.986}{0.00355}$$



A note about sampling and arithmetic*

- Converting values in 16-bit MCUs

$$V_{\text{TEMP}} = N_{\text{ADC}} \times \frac{V_{R+} - V_{R-}}{4095} \quad \text{TEMP}_C = \frac{V_{\text{TEMP}} - 0.986}{0.00355}$$

```
vtemp = adccount/4095 * 1.5;  
tempc = (vtemp-0.986)/0.00355;  
→ tempc = 0
```

- Fixed point operations
 - Need to worry about underflow and overflow
- Floating point operations
 - They can be costly on the node

Use anti-aliasing filters on ADC inputs to ensure that Shannon-Nyquist is satisfied

- Aliasing
 - Different frequencies are indistinguishable when they are sampled.

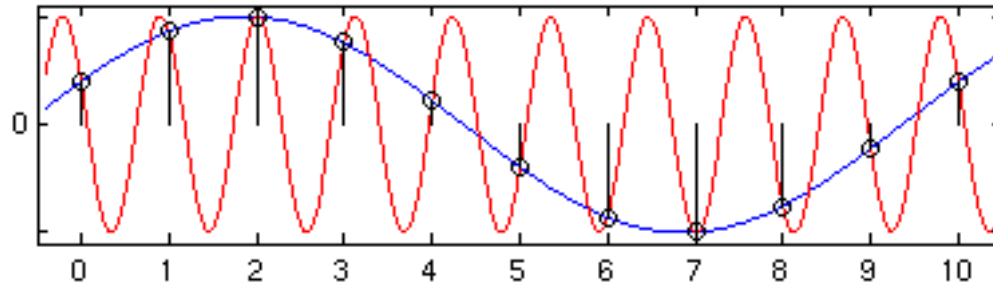

- Condition the input signal using a low-pass filter
 - Removes high-frequency components
 - (a.k.a. anti-aliasing filter)

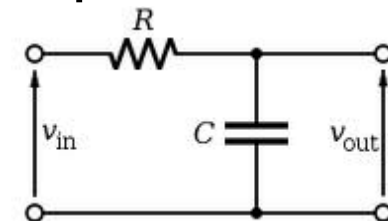

Designing the anti-aliasing filter

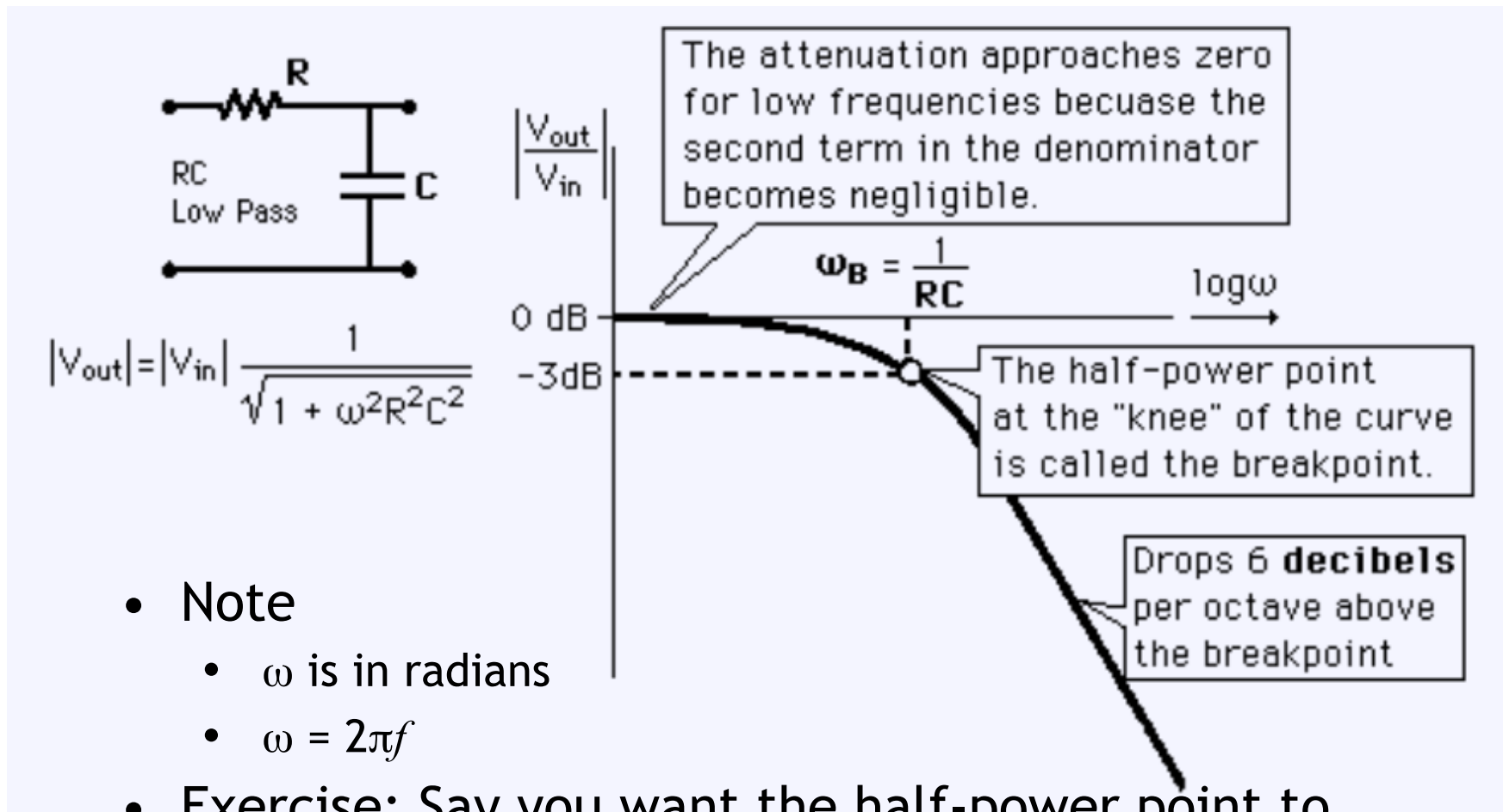

- Note
 - ω is in radians
 - $\omega = 2\pi f$
- Exercise: Say you want the half-power point to be at 30Hz and you have a 0.1 μF capacitor. How big of a resistor should you use?

Do I really need to condition my input signal?



- Short answer: Yes.
- Longer answer: Yes, but sometimes it's already done for you.
 - Many (most?) ADCs have a pretty good analog filter built in.
 - Those filters typically have a cut-off frequency just above $\frac{1}{2}$ their *maximum* sampling rate.
 - Which is great if you are using the maximum sampling rate, less useful if you are sampling at a slower rate.

Oversampling



- One interesting trick is that you can use oversampling to help reduce the impact of quantization error.
 - Let's look at an example of oversampling plus dithering to get a 1-bit converter to do a much better job...
 - (done on board)

Can use dithering to deal with quantization



- Dithering
 - Quantization errors can result in large-scale patterns that don't accurately describe the analog signal
 - Oversample and dither
 - Introduce random (white) noise to randomize the quantization error.

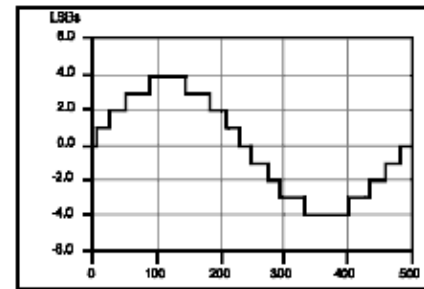

a. Dither disabled; no averaging

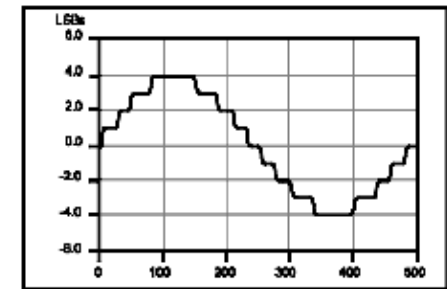

b. Dither disabled; average of 50 acquisitions

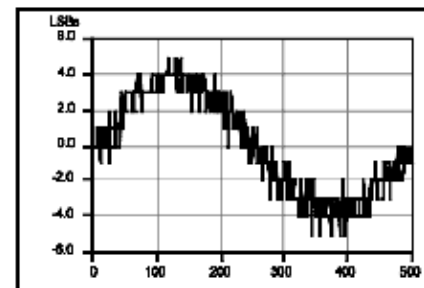

c. Dither enabled; no averaging

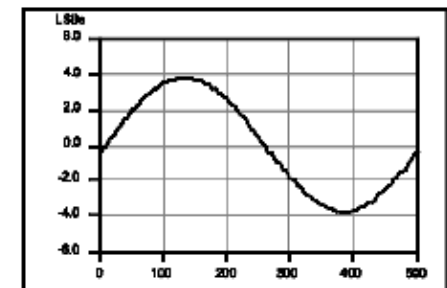

d. Dither enabled; average of 50 acquisitions



Direct Samples



Dithered Samples

Lots of other issues



- Might need anti-imaging (reconstruction) filter on the output
- Cost, speed (, and power):
- Might be able to avoid analog all together
 - Think PWM when dealing with motors...

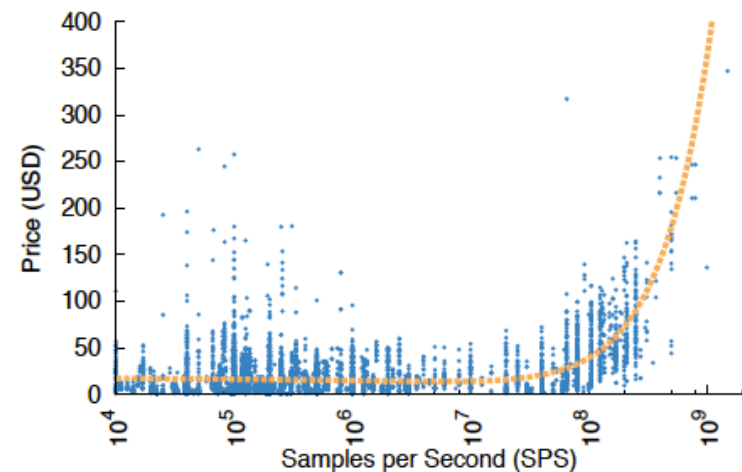

How do ADCs and DACs work?



DAC #1: Voltage Divider

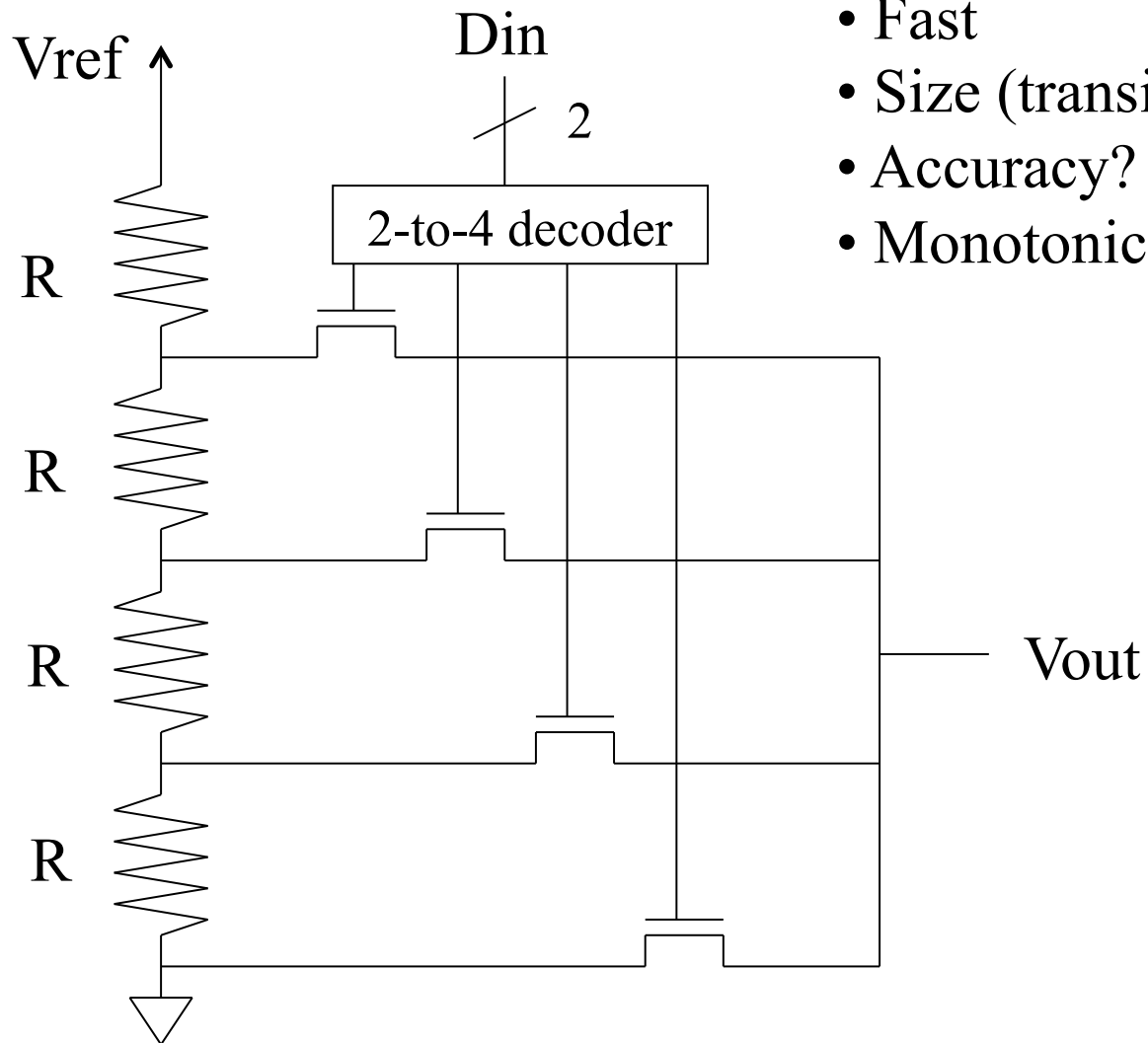

- Fast
- Size (transistors, switches)?
- Accuracy?
- Monotonicity?

DAC #2: R/2R Ladder

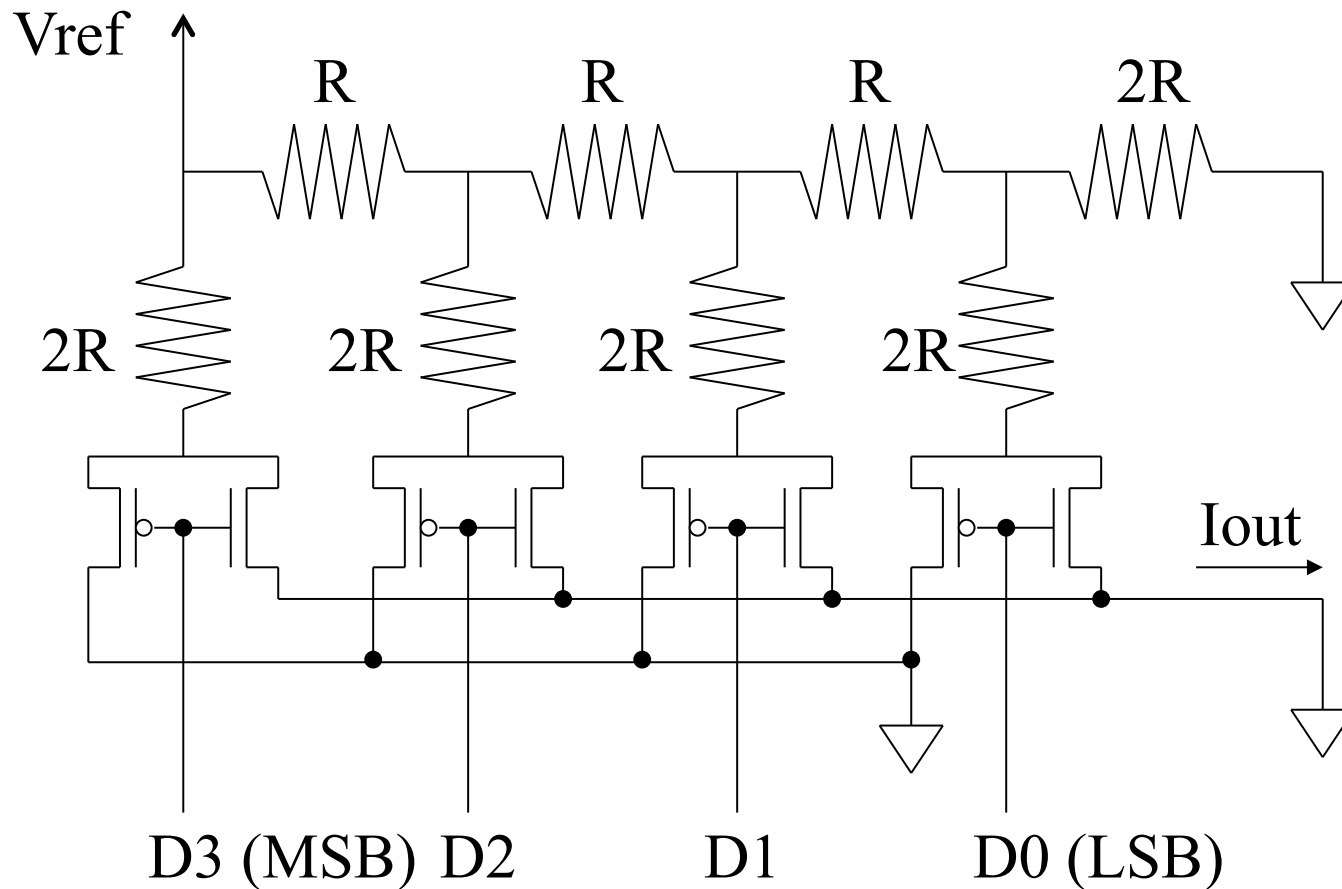

- Size?
- Accuracy?
- Monotonicity? (Consider 0111 \rightarrow 1000)

DAC output signal conditioning*

- Often use a low-pass filter
- May need a unity gain op amp for drive strength

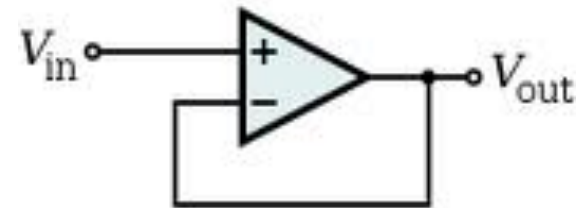
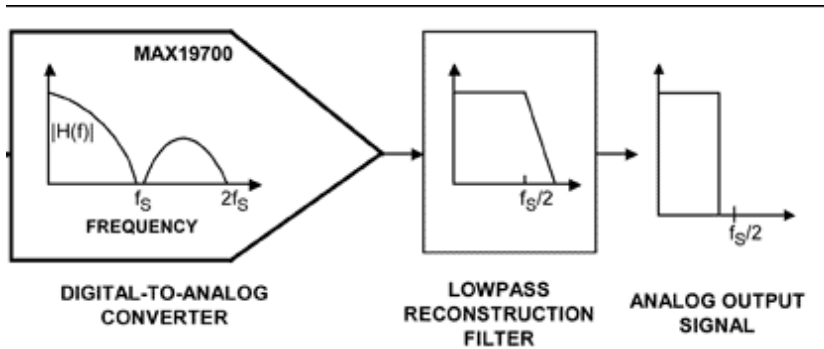

ADC #1: Flash

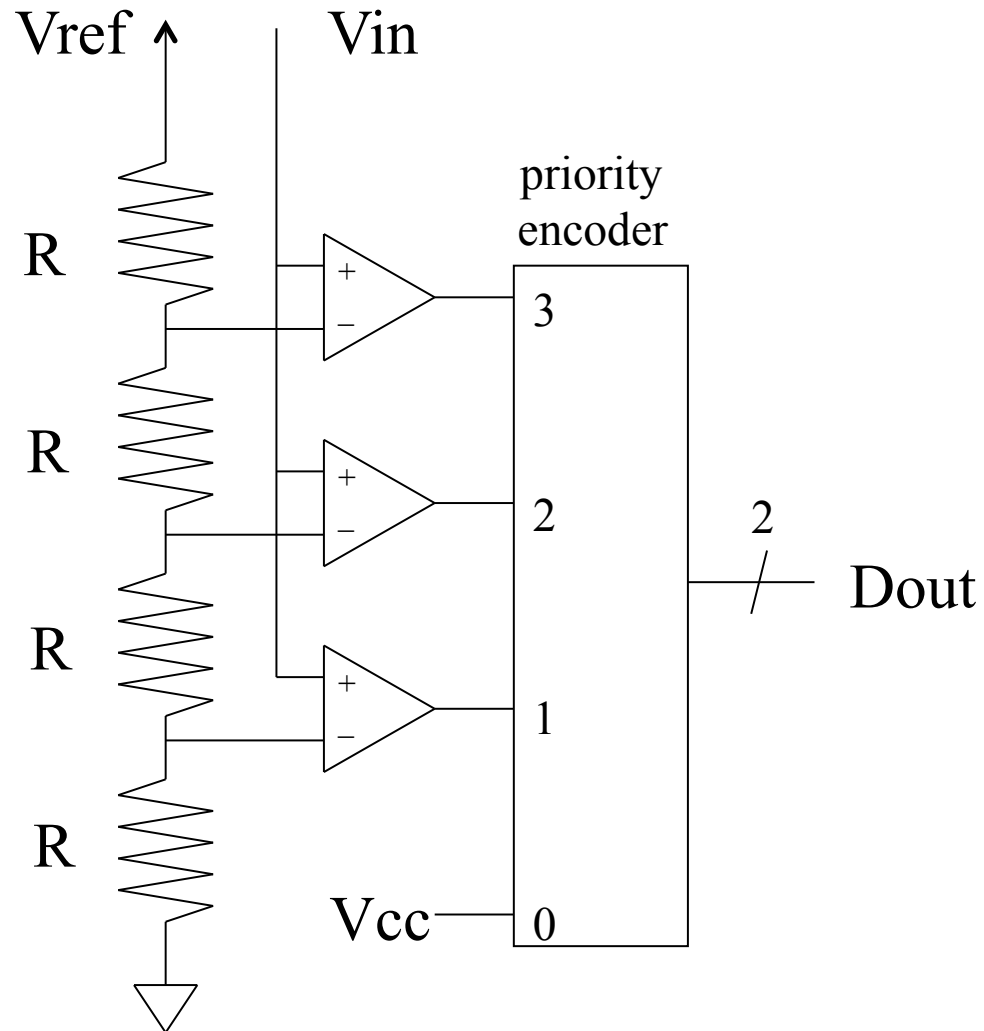

ADC #2: Single-Slope Integration

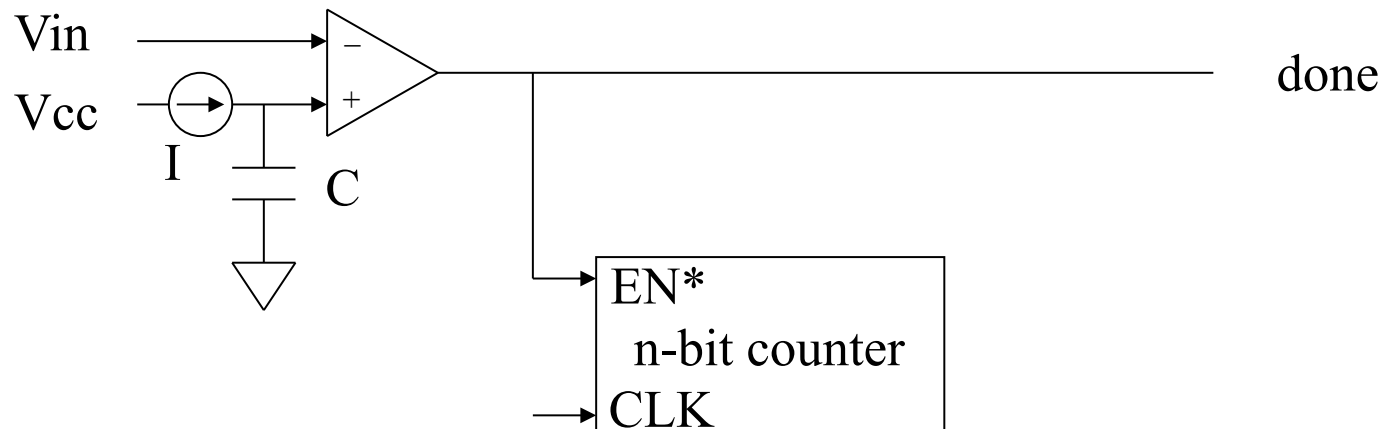

- Start: Reset counter, discharge C .
- Charge C at fixed current I until $V_c > V_{in}$. How should C , I , n , and CLK be related?
- Final counter value is D_{out} .
- Conversion may take several milliseconds.
- Good differential linearity.
- Absolute linearity depends on precision of C , I , and clock.

ADC #3: Successive Approximation (SAR)*

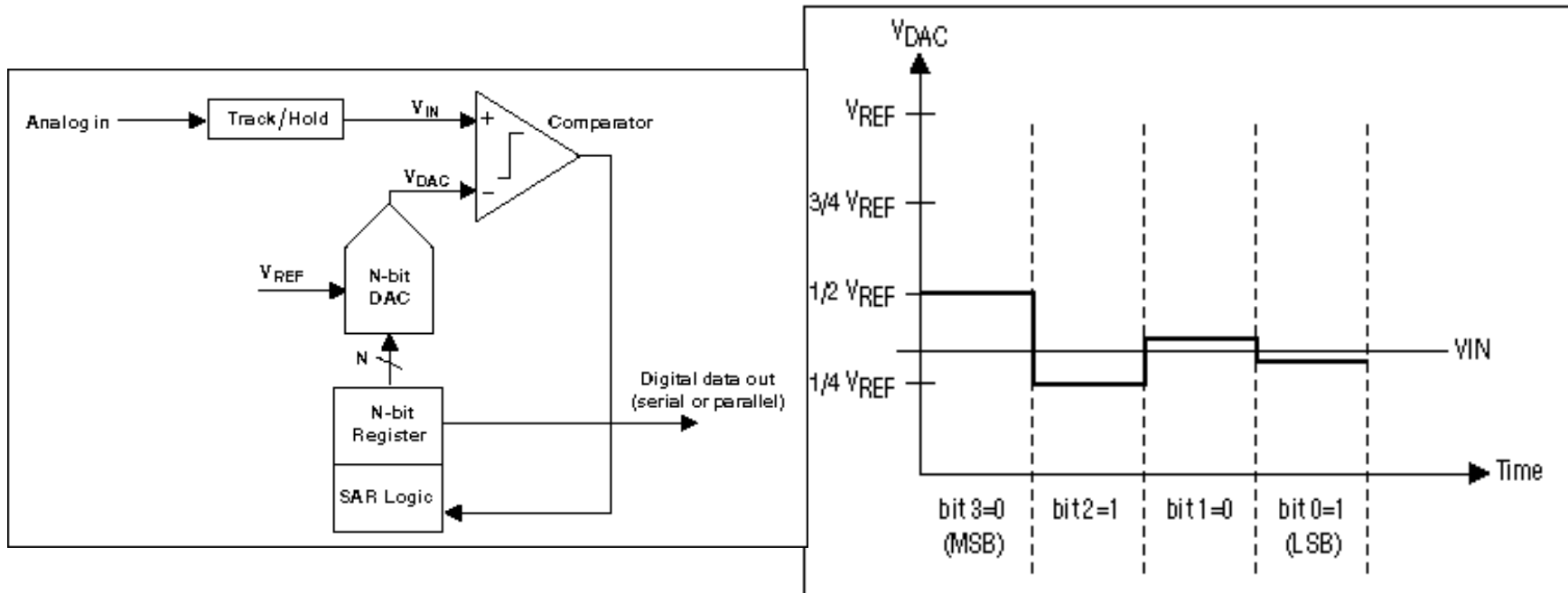

1 Sample \rightarrow Multiple cycles

- Requires N-cycles per sample where N is # of bits
- Goes from MSB to LSB
- Not good for high-speed ADCs

Errors and ADCs

- Figures and some text from:
 - Understanding analog to digital converter specifications. By Len Staller
 - <http://www.embedded.com/showArticle.jhtml?articleID=60403334>
- Key concept here is that the specification provides *worst case* values.

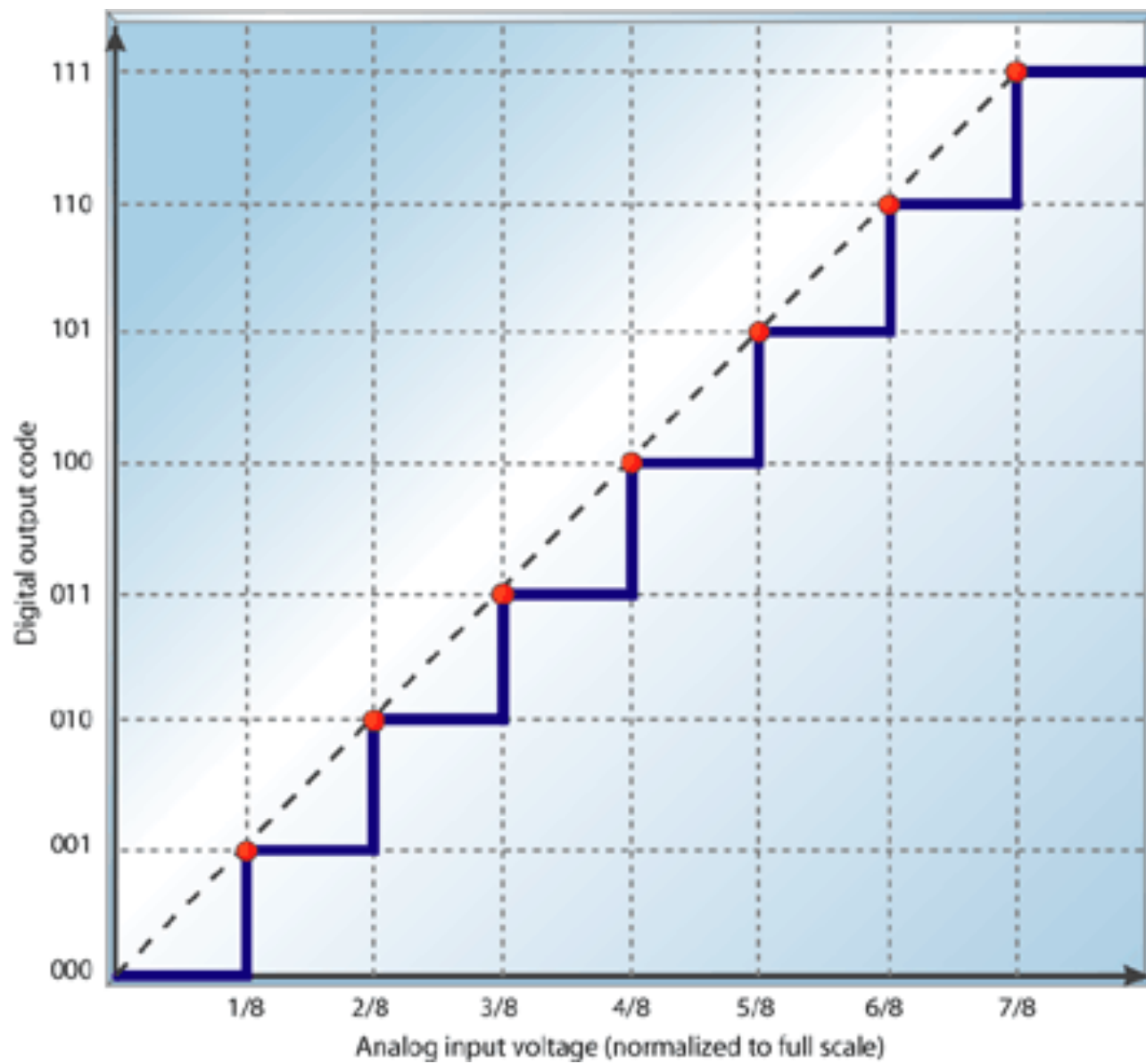

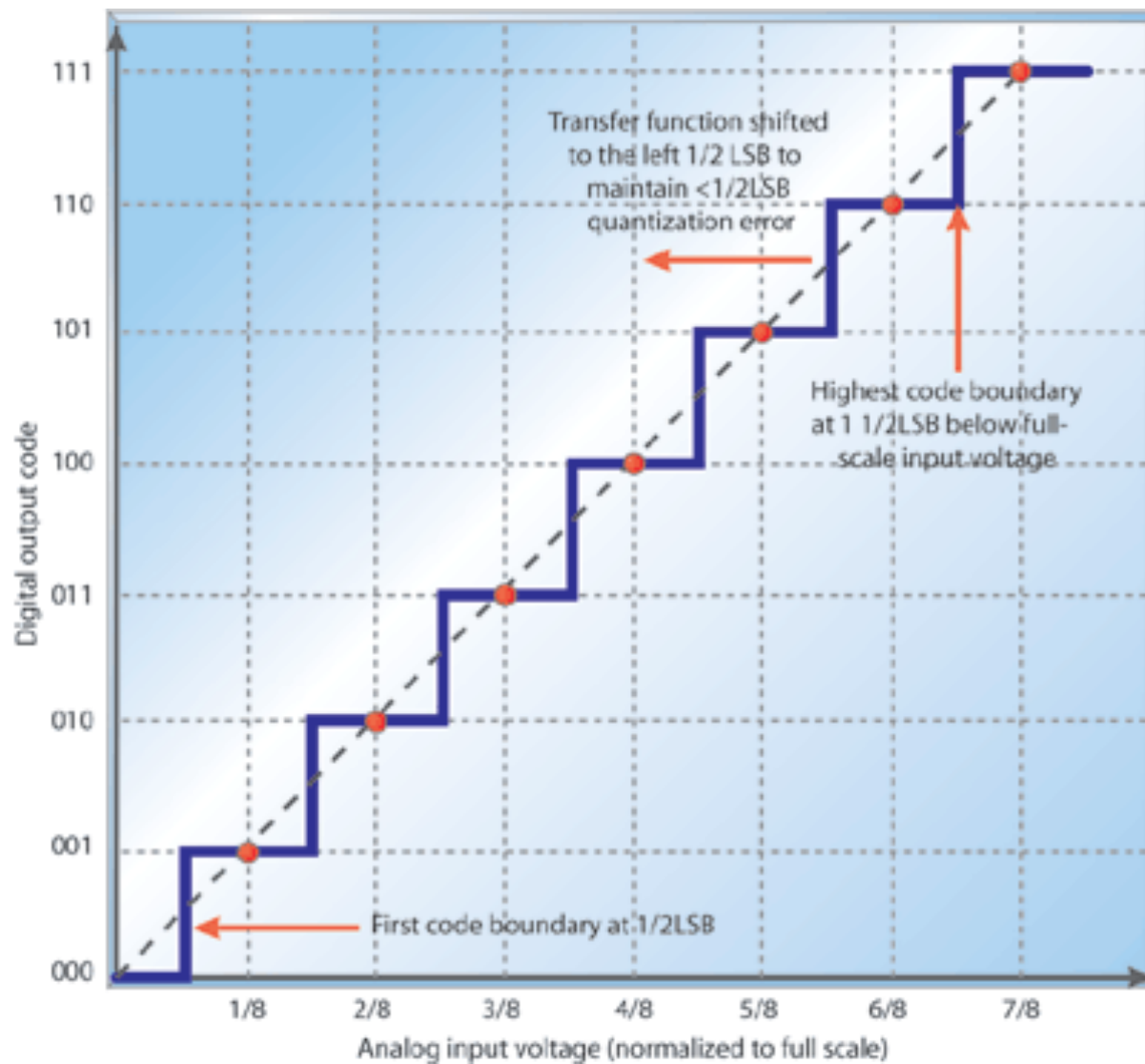

Integral nonlinearity

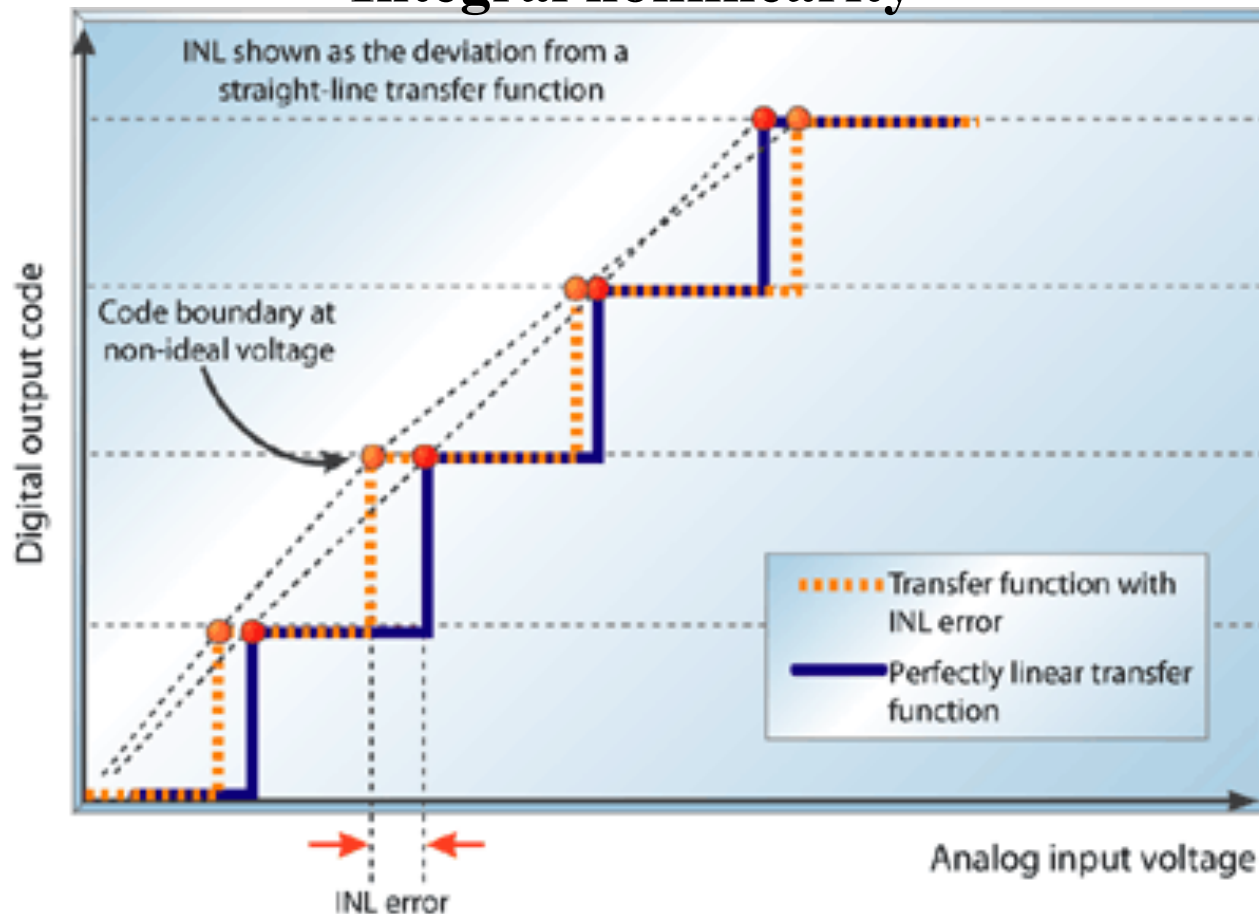

The *integral nonlinearity (INL)* is the deviation of an ADC's transfer function from a **straight line**. This line is often a best-fit line among the points in the plot but can also be a line that connects the highest and lowest data points, or endpoints. INL is determined by measuring the voltage at which all code transitions occur and comparing them to the ideal. The difference between the ideal voltage levels at which code transitions occur and the actual voltage is the INL error, expressed in LSBs. INL error at any given point in an ADC's transfer function is the accumulation of all DNL errors of all previous (or lower) ADC codes, hence it's called *integral* nonlinearity.

Differential nonlinearity

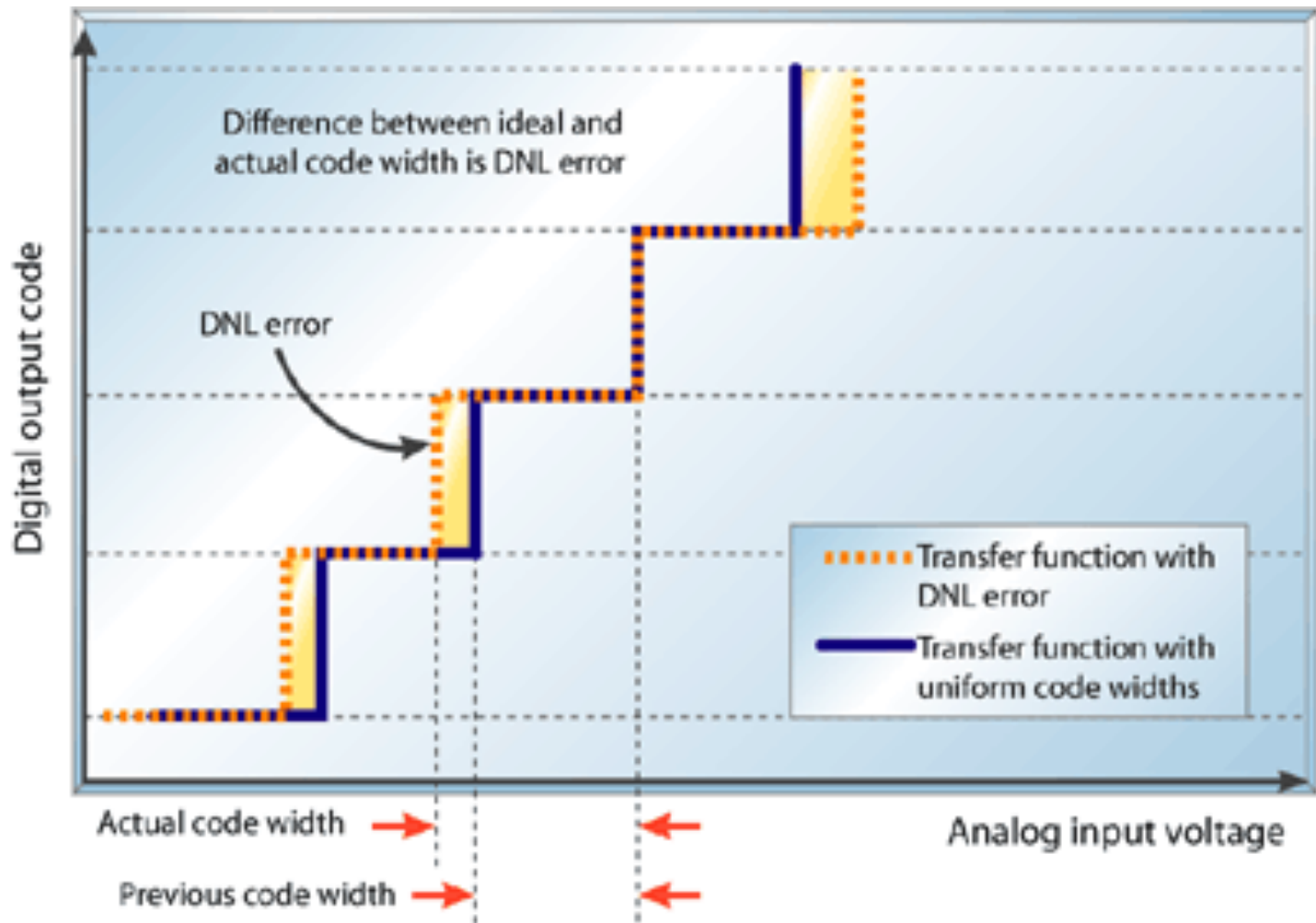

DNL is the worst cases variation of actual step size vs. ideal step size.

It's a promise it won't be worse than X.

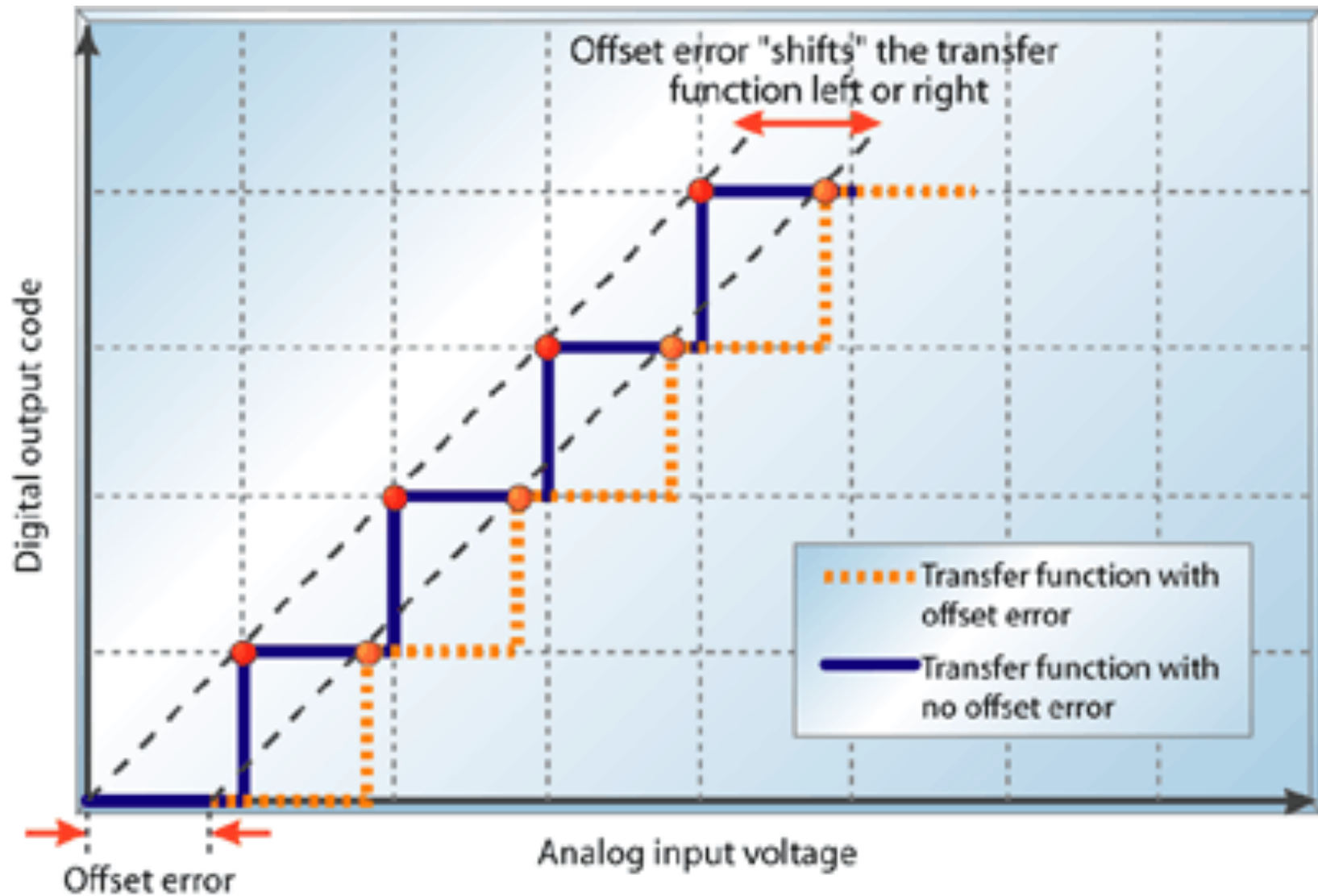

Sometimes the intentional $\frac{1}{2}$ LSB shift is included here!

Full-scale error is also sometimes called “gain error”

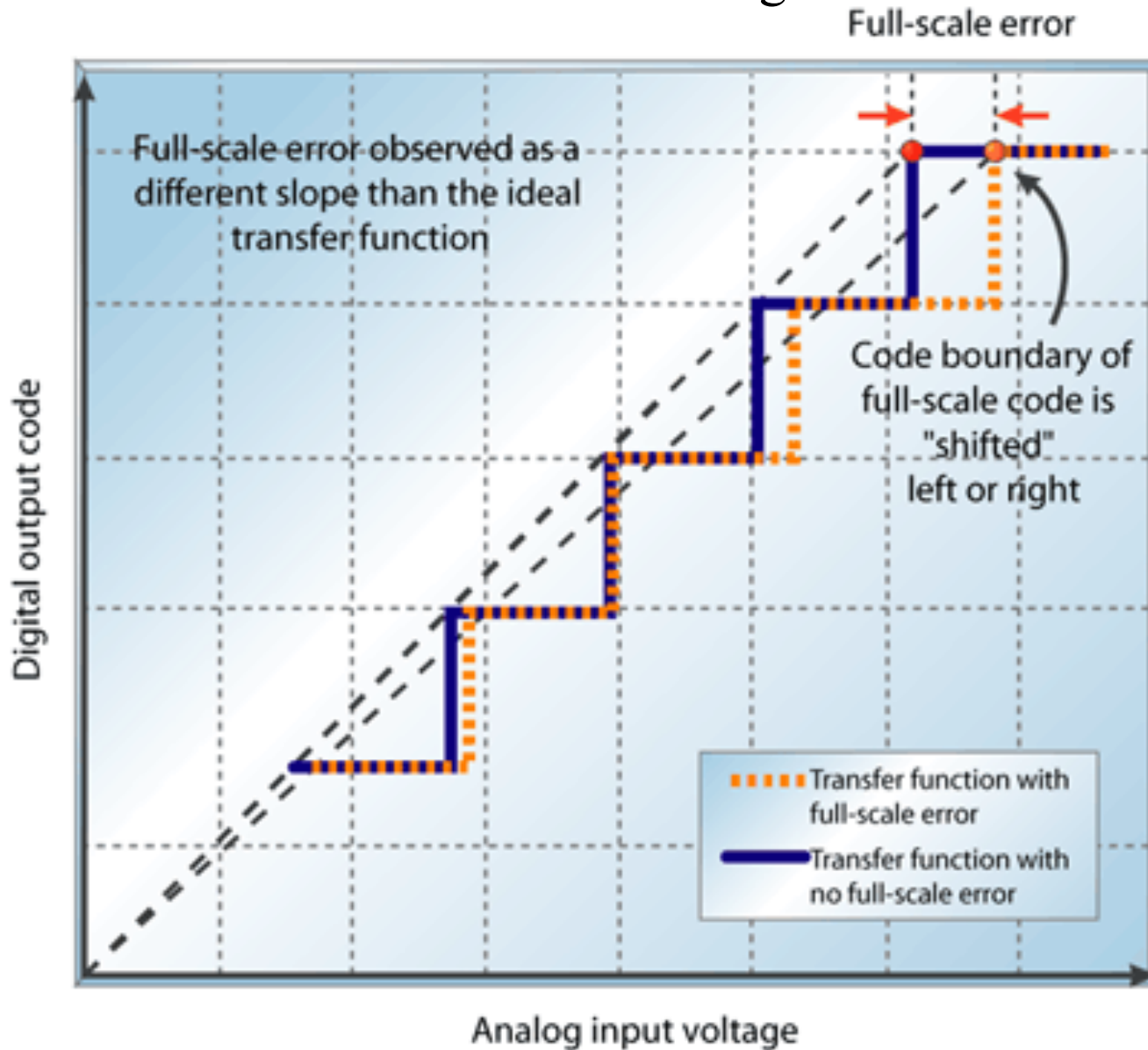

full-scale error is the difference between the ideal code transition to the highest output code and the actual transition to the output code when the offset error is zero.

Errors



- Once again: Errors in a specification are worst case.
 - So if you have an INL of $\pm .25$ LSB, you “know” that the device will never have more than .25 LSB error from its ideal value.
 - That of course assumes you are operating within the specification
 - Temperature, input voltage, input current available, etc.
- INL and DNL are the ones I expect you to work with
 - Should know what full-scale error is