

Figure 1: System I/O map.

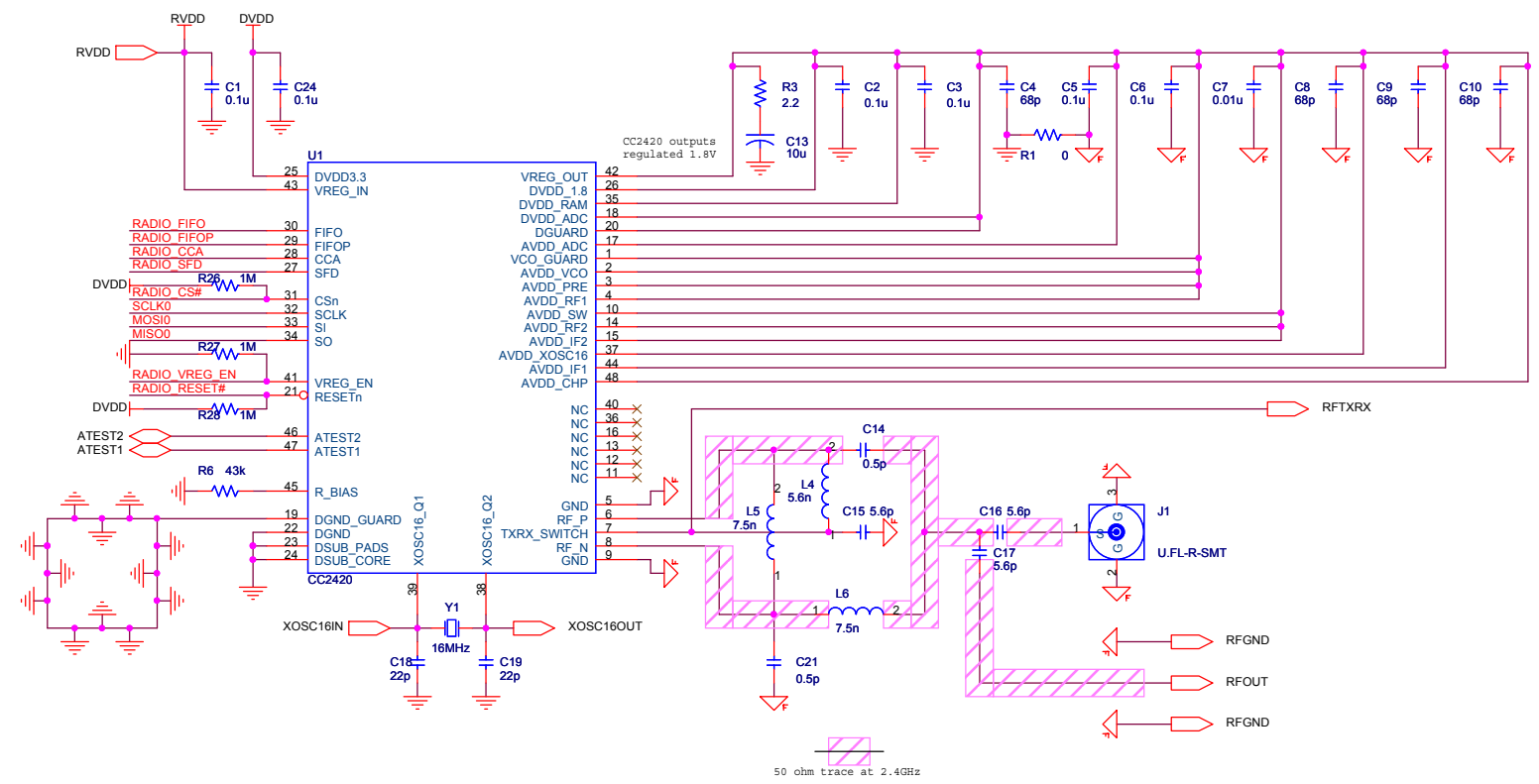
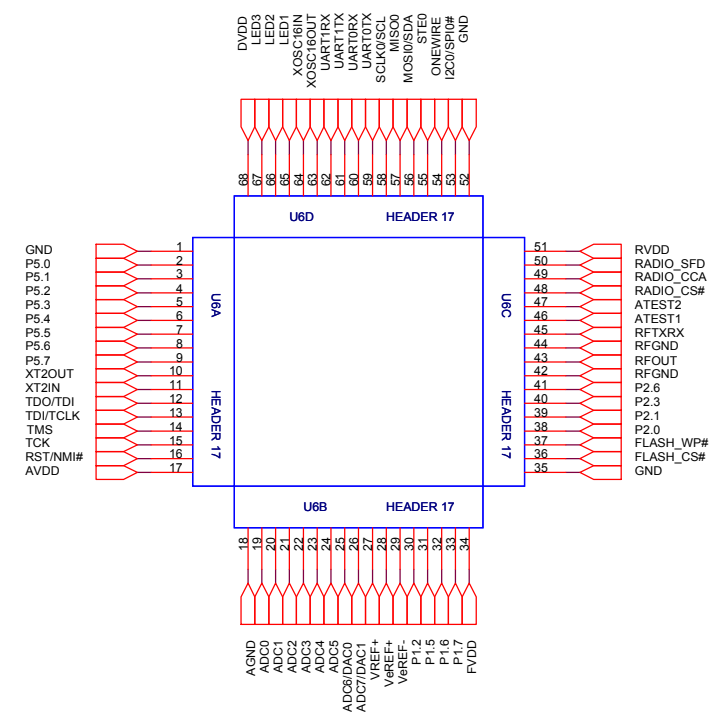

Figure 2: System PCB floorplan.

- DESIGN NOTES
1. All discretes are 0201 unless only available in larger sizes.
 2. Microcontroller, radio, and flash all have separate power.
 3. Split ground planes as shown in Figure 2.
 4. Use LCC's footprint for PCB substrate.
 5. MCU and radio pin 1 denoted by small circle.



Title		Epic Core
Size	Document Number	Rev
C	(C) Copyright 2006: Prabal Dutta	A
Date:	Tuesday, March 20, 2007	Sheet 1 of 1