**Small Autonomous Robot Actuator (SARA): A Solar-powered Wireless
MEMS Gripper**

by Alex Moreno

Research Project

Submitted to the Department of Electrical Engineering and Computer Sciences,
University of California at Berkeley, in partial satisfaction of the requirements for the
degree of **Master of Science, Plan II**.

Approval for the Report and Comprehensive Examination:

Committee:

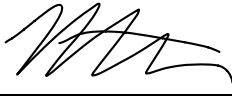

Professor Kristofer S.J. Pister
Research Advisor

5/14/21

(Date)



Professor Ali M. Niknejad
Second Reader

5/14/2021

(Date)

Small Autonomous Robot Actuator (SARA): A Solar-powered Wireless MEMS Gripper

by

Alex Moreno

A thesis submitted in partial satisfaction of the

requirements for the degree of

Master of Science

in

Engineering – Electrical Engineering and Computer Sciences

in the

Graduate Division

of the

University of California, Berkeley

Committee in charge:

Professor Kristofer S.J. Pister, Chair

Professor Ali M. Niknejad, Co-chair

Spring 2021

Small Autonomous Robot Actuator (SARA): A Solar-powered Wireless MEMS Gripper

Copyright 2021
by
Alex Moreno

Abstract

Small Autonomous Robot Actuator (SARA): A Solar-powered Wireless MEMS Gripper

by

Alex Moreno

Master of Science in Engineering – Electrical Engineering and Computer Sciences

University of California, Berkeley

Professor Kristofer S.J. Pister, Chair

Professor Ali M. Niknejad, Co-chair

Solar-powered actuation of a 15 mN electrostatic MEMS gripper was demonstrated while wirelessly triggered by IEEE 802.15.4 RF signals. The solar-powered gripper was shown to actuate at a rate of 640 $\mu\text{m}/\text{s}$. The complete system is composed of three capacitors and three chips: MEMS gripper, microprocessor/crystal-free radio, and solar cell array/high voltage buffer. Control signals for the electrostatic inchworm motors originate from the $3 \times 2 \times 0.3 \text{ mm}^3$ chip with an ARM Cortex-M0 microprocessor and are passed through 119 V high voltage buffers. Power for all components, including the crystal-free radio, microprocessor, and 119 V buffers, is supplied by a multi-output array of solar cells on a CMOS SOI chip under $200 \text{ mW}/\text{cm}^2$ irradiation.

Para mi mama, Sara.

Gracias por tu apoyo constante y determinación para darnos la educación que no pudiste tener.

To my mom, Sara.

Thank you for your constant support and determination to give us the education you were not able to have.

Contents

Contents	ii
List of Figures	iii
List of Tables	iv
1 Introduction	1
2 System Description	4
2.1 SC μ M: Crystal-Free Radio and Microprocessor	4
2.2 Zappy 2: Solar Cell and High Voltage Buffers	5
2.3 Gripper: MEMS SOI 15 mN Gripper	6
3 System Operation	8
3.1 Phase 1: Optical Calibration	8
3.2 Phase 2: Solar Power and LC Calibration	8
3.3 Phase 3: Receive Packets	9
3.4 Phase 4: Transmit acknowledgement	10
3.5 Phase 5: MEMS Gripper Actuation	11
4 Conclusion	16
Bibliography	17

List of Figures

1.1	MEMS Gripper, HV Buffer & Solar Cell Array Chip, Single Chip Micro Mote (left to right). Two SC μ M chips are stacked due to initial SC μ M malfunctioning. The dimensions of SARA are $9.5 \times 31.55 \text{ mm}^2$	2
1.2	System block diagram including power domains, phases of operation, and all components.	3
2.1	Model used to maintain proper operating voltages and functionality of SARA. Typically $I_{\text{quiescent}}=350 \mu\text{A}$ and $I_{\text{transient}}=1250 \mu\text{A}$ during radio operation.	6
3.1	Crystal-free radio local oscillator frequency vs. VBAT voltage at a fixed LC tuning setting. The blue lines shows the ± 40 ppm tolerance band of the 802.15.4 standard and the green lines shows the ± 150 ppm tolerance of the OpenMote.	10
3.2	VBAT current during wireless 802.15.4 receive (200 mW/cm^2 irradiation; $47 \mu\text{F}$ VBAT bypass capacitor). ϕ_1 : Low power ($F_{\text{cortex}}=78 \text{ kHz}$), ϕ_2 : RX with radio on, ϕ_3 : periodic wake up to $F_{\text{cortex}}=5 \text{ MHz}$	11
3.3	VBAT voltage vs. time during wireless 802.15.4 transmit (200 mW/cm^2 irradiation; $100 \mu\text{F}$ bypass capacitor). The dashed lines indicate the 4 ms period when the radio was enabled.	12
3.4	VBAT current during wireless 802.15.4 transmit (200 mW/cm^2 irradiation; $20 \mu\text{F}$ bypass capacitor). Phases: ϕ_1 : $F_{\text{cortex}}=78 \text{ kHz}$ low power mode and UART logging before transmit, ϕ_2 : Transmit 10 byte packet, ϕ_3 : $F_{\text{cortex}}=5 \text{ MHz}$ idle state	12
3.5	Measured gripper leakage current under DC supply vs. HV buffer DC voltage, and Zappy2 VDDHPV supply current vs. VDDHPV voltage under 100 mW/cm^2 (measured) and 200 mW/cm^2 irradiation (estimated). Red intersections represent operating points of the system at 100 mW/cm^2 and 200 mW/cm^2 irradiation while closing the gripper at very slow speeds approaching zero and duty cycles approaching 100%.	14
3.6	Toggling of HV buffers driving MEMS gripper at 200 mW/cm^2 irradiation. SC μ M GPIO pins 4 and 5 are enabling/disabling 59 V HV buffered outputs D1 and D2 (respectively) on Zappy2. GPIOs toggling at 5.9 Hz with a 60% duty cycle at a 180 degree phase offset from each other.	15

List of Tables

1.1	SARA Weight Specifications	2
2.1	SC μ M System Clocks	4
2.2	SC μ M Operating Current (1.5 V)	5
2.3	Solar Output Specifications at 100 mW/cm ² Irradiation	6
3.1	GPIO _{output} Specifications	13

Acknowledgments

I would like to acknowledge all of the people involved in the development of

- SCUM: Filip Maksimovic, Brad Wheeler, David C. Burnett, Osama Khan, Sahar Mesri, Ioana Suciu (Universitat Oberta de Catalunya), Lydia Lee, Arvind Sundararajan, Bob Zhou, Rachel Zoll, Andrew Ng, Tengfei Chang (Inria, EVA Team), Xavier Villajosana (Universitat Oberta de Catalunya), Thomas Watteyne (Inria, EVA Team), Ali Niknejad, and Kristofer S.J. Pister
- Zappy2: Jan Rentmeister (Dartmouth), Professor Jason Stauth (Dartmouth)
- The MEMS Gripper: Daniel Teal, Hani Gomez, Craig Schindler, Dillon Acker-James and Wei Li

I would like to give a special thanks to the talented undergraduate researcher Austin Patel. It has been a privilege working with him. I have appreciated his kind personality, dedication and perseverance to getting what needs to be done done (e.g. 3 a.m. debug sessions, weekend work marathons, conference paper deadlines, etc).

I would like to thank my partner, Sanchala, for her support, conversations, laughter and words of encouragement during the tough times.

I would like to thank my advisors Kris and Ali for believing in me and pushing me to be a better researcher.

Last but not least, I would like to thank my dad, my mom, brother and sister. I know moving across the country and seeing each other one or two times a year was a big change. They were always there with a bright smile when I went home. Thank you for listening to my struggles and celebrating my victories. I dedicated this project to my mother Sara. She has been a leader in our family's education. If it wasn't for her relentless determination to get us the education she was never allowed to have I would not be where I am today.

This work was supported by the National Science Foundation Graduate Research Fellowship Program under Grant No. DGE 1752814. Any opinions, findings, and conclusions or recommendations expressed in this material are those of the authors and do not necessarily reflect the views of the National Science Foundation.

Chapter 1

Introduction

One ideal for an autonomous microrobotic system is one composed of motors, mechanisms, sensing, computation, communication, and power, which is able to interact with its environment and the internet in an intelligent manner. Much progress has been made in the development of all of the required components, and in the integration of full systems. This thesis reports a modest level of autonomy in a modular combination of a small number of components, with application to a broader set of microrobots. The motor and mechanism used here is a MEMS gripper described in [25]. The gripper is a single degree-of-freedom actuator, very simple from a robotics perspective. But it is made in a MEMS fabrication process which has been used to fabricate more complicated robot structures, such as jumpers [26] and a twelve degree-of-freedom hexapod [8], as well as a quadthrustrer ionocraft [10]. The jumper and walker use the same basic electrostatic inchworm motor as the gripper. The high voltage chip used here, Zappy2, was designed to drive this type of motor.

Previous work on untethered systems has shown that small robots are able to accomplish interesting tasks in healthcare and bioengineering [27], and construction [12]. In many cases these untethered robots might benefit from a wireless microgripper attachment, as would some of the autonomous robots below.

There are many small autonomous robot systems in the multiple cubic inch size range [22, 21, 2]. Communication is a key enabler in several of these systems [22, 9]. Indeed, communication may be the only area in which man-made microrobots can outperform their natural counterparts. While IR communication is simple and useful for local operations, RF communication allows longer-range, multi-hop mesh networks, and easier integration into existing networks and infrastructure. The Bluetooth chip used by Iyer, et al. [13] allowed them to send images over 120 meters. The radio used by Sabelhaus et al. [22] speaks the 802.15.4 PHY and MAC protocol natively. This protocol is the basis of a highly reliable low power mesh networking communication stack, OpenWSN [31]. The Single Chip micro Mote, SC μ M, was designed to perform the computation and communication required by swarms of simple microrobots, and is able to run the OpenWSN stack [4]. It has some features in common with the chip developed by Zhang et al. [35].

There have been several autonomous microrobots in the sub-gram size range, mostly

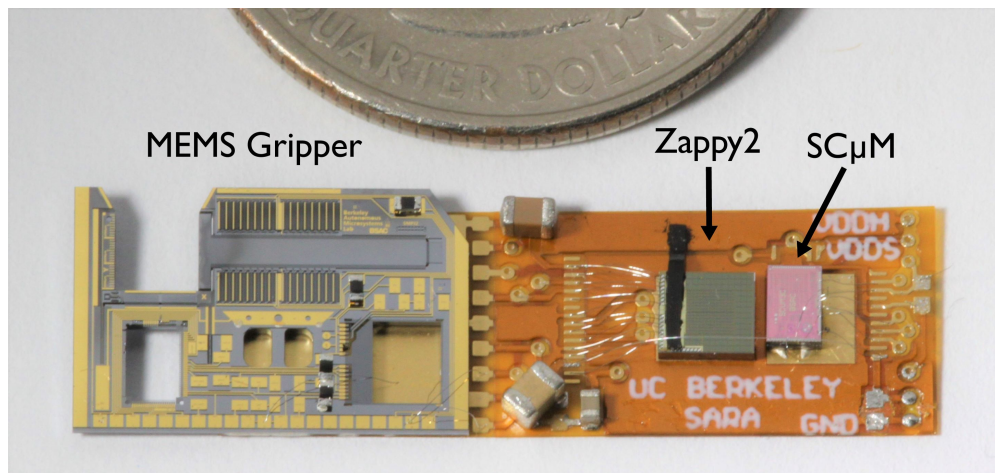

Figure 1.1: MEMS Gripper, HV Buffer & Solar Cell Array Chip, Single Chip Micro Mote (left to right). Two SC μ M chips are stacked due to initial SC μ M malfunctioning. The dimensions of SARA are $9.5 \times 31.55 \text{ mm}^2$

Table 1.1: SARA Weight Specifications

Item	Mass (mg)
Empty Flex PCB	71.8
SC μ M (Stacked)	8.6
Zappy 2	17.3
MEMS Gripper	137.9
0402 Capacitor (22 μ F VDDIO)	3.8
0805 Capacitor (100 μ F VBAT)	26.2
0805 Capacitor (100 nF VDDH)	17.2
Solder and wirebonds	3.1
Total Mass	285.9

aerial vehicles. The 10 mg robot built by Hollar et al. [11] used inchworm motors and a solar cell array and was able to do autonomous pushups, with a small amount of lateral motion, under roughly one sun of illumination. The controller was a simple CMOS finite state machine, with no sensor feedback. The 300 mg robot built by Churaman et al. [5] was able to jump 11 body lengths when triggered by an on-board light sensor. The logic was hard-wired. James et al. [15] were the first to achieve takeoff, however briefly, of a 190 mg robot under 200 suns of illumination. The 259 mg robot built by Jafferis et al. [14] achieved many body lengths of autonomous flight under only a few suns of illumination. Both of these last two flapping wing robots used open-loop control, but included a digital microcontroller, indicating that future sensor integration will be possible.

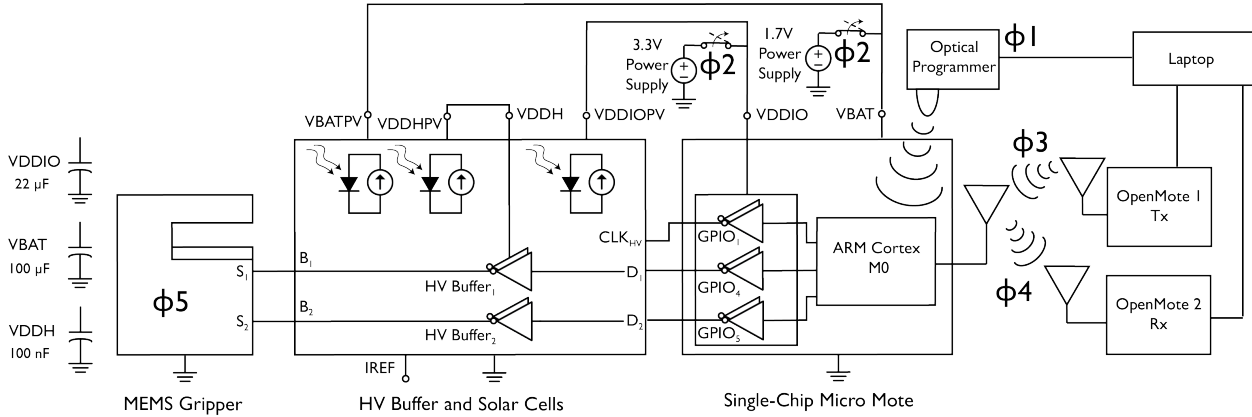

Figure 1.2: System block diagram including power domains, phases of operation, and all components.

Previous work has demonstrated the operation of electrostatic inchworm motors using multi-junction solar cell arrays [23], coupled with an external silicon leg-sweeping mechanism. Bellew et al. [1] demonstrated the integration of solar cells, CMOS, and MEMS into a single process, pointing to a future in which the size, weight, and frustration associated with multi-chip assembly is minimized.

The work described here is a step toward demonstrating standards-compatible mesh-networked swarms of centimeter-scale microrobots.

Chapter 2

System Description

The SARA robot consists of three chips and three capacitors. In addition, two OpenMote B CC2538 IoT devices were used for RF communication between SARA and a laptop, one for sending commands to SC μ M and the other for receiving from SC μ M [30]. Additionally, a Teensy 3.6 microcontroller with an infrared LED was used to optically program and calibrate the SC μ M chip [32]. The block diagram of the system can be seen in Figure 1.2.

2.1 SC μ M: Crystal-Free Radio and Microprocessor

SC μ M is a $3 \times 2 \times 0.3 \text{ mm}^3$ CMOS SoC featuring an ARM Cortex-M0 microprocessor, BLE transmitter, and a standards-compatible crystal-free 802.15.4 transceiver [17]. The chip also features an ADC, 16 0.8 V to 3.6 V GPIOs, and an optical receiver used for optical programming and calibration. SC μ M requires only one 1.2 V to 1.8 V power supply connected to VBAT to operate [17], but the GPIOs may be driven from a separate supply, VDDIO. In order for SC μ M to properly drive the high voltage buffers on Zappy2, the solar cell array provides $\text{VBAT} = 1.8 \text{ V}$ and $\text{VDDIO} = 3.5 \text{ V}$.

Table 2.1: SC μ M System Clocks

Clock	Purpose
20 MHz RC	Source for Cortex microprocessor
2.4 GHz LC	Dictates radio channel frequency
2 MHz RC	Radio chipping clock
64 MHz RC	Sample RF intermediate frequency
500 kHz RC (derived)	User-defined interrupts

By removing the crystal reference, SC μ M is able to further reduce size and cost of microbotic devices. In place of a crystal reference, SC μ M uses on-chip CMOS oscillators as

Table 2.2: SC μ M Operating Current (1.5 V)

State	Approximate Current
5 MHz Clock Rate (Normal)	350 μ A
5 MHz Clock Rate (Radio on)	1.6 mA
78 kHz Clock Rate (Low power)	200 μ A

detailed in Table 2.1. However, this means that on-chip oscillators need to be calibrated to ensure standards compatible 802.15.4 radio operation. Notably, the 2.4 GHz LC oscillator used to set the local oscillator (LO) at the desired radio channel frequency is configured using three, 5-bit capacitive tuning DACs referred to as the coarse, mid, and fine tuning settings. Other calibrated clocks include the 20 MHz CPU clock, 2 MHz chipping clock, and 64 MHz receiver intermediate frequency sampling clock. Calibration of these clocks has been successfully demonstrated using several different approaches, including an optical programmer [32], temperature-based calibration [34, 18], and RF-based calibration using only packets overheard [28, 29, 3]. The work reported here used the optical programmer.

During normal operation the 20 MHz RC oscillator is divided down to 5 MHz for use as the clock for the Cortex microprocessor. For lower power consumption this oscillator is divided to 78 kHz. The current consumption at these various operating conditions can be seen in Table 2.2.

2.2 Zappy 2: Solar Cell and High Voltage Buffers

Zappy2 contains the photovoltaic (PV) arrays that power the robot and high voltage buffers to drive the motors. The 3.26×3.5 mm² chip is fabricated in a 650 V trench-isolated CMOS process and contains more than two hundred PV cells [20]. These PV cells are grouped in series to provide three voltage domains: one to power SC μ M (VBATPV; 1.8 V), one as a reference for the SC μ M’s GPIOs (VDDIOPV; 3.5 V), and one as a high voltage rail to power the electrostatic motors on the MEMS gripper (VDDHPV; 119 V). The performance characteristics of the solar cell arrays are shown in Table 2.3. Three capacitors of size 100 μ F, 22 μ F, and 100 nF are used to maintain voltage across VBAT, VDDIO, and VDDH, respectively (Figure 1.2). In the SARA robot, the lowest allowable successful operating voltages of VBAT, VDDIO and VDDH were measured to be 1.3 V, 3.3 V and 40 V, respectively.

Zappy2 also contains four high voltage (HV) buffers, two of which are needed to drive a single inchworm motor. These buffers hard switch their outputs between 0 V and VDDHPV at a rate determined by the switching of the input signals. SC μ M uses two GPIOs to drive two buffers, and a third GPIO to generate the CLK_{HV}=100 kHz source needed for the Zappy2 internal digital state machine.

Hard switching the HV lines is sub-optimal for electrical to mechanical conversion effi-

Table 2.3: Solar Output Specifications at 100 mW/cm² Irradiation

	VBATPV	VDDIOPV	VDDHPV
V _{OC}	1.8 V	3.5 V	119 V
I _{SC}	280 μ A	16 μ A	2.4 μ A

ciency, and because it requires significant capacitance on the HV supply to avoid drooping in the supply voltage. Both of these problems can be solved using an improved version of the HV chip [16], but for SARA we simply added a HV capacitor that was large compared to the load capacitance of the electrostatic actuators, roughly 70 pF.

For this SARA integration, the solar array is provided with 200 mW/cm² irradiation to provide VBATPV to SC μ M with 560 μ A at 1.86 V.

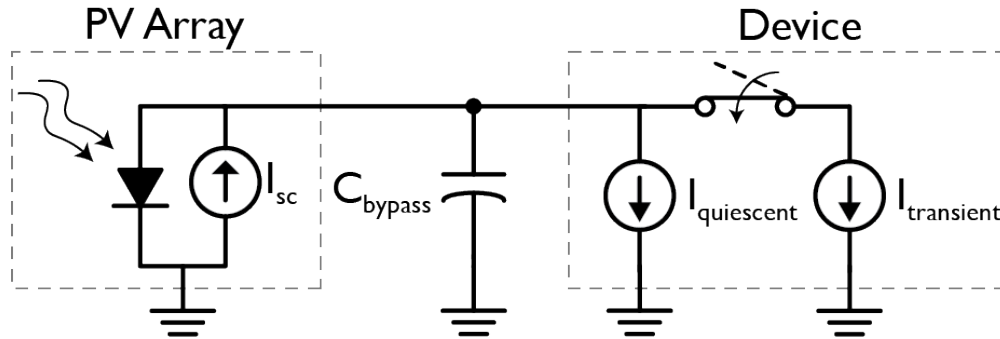

Figure 2.1: Model used to maintain proper operating voltages and functionality of SARA. Typically $I_{quiescent}=350 \mu\text{A}$ and $I_{transient}=1250 \mu\text{A}$ during radio operation.

Figure 2.1 shows a simple model of the VBAT supply and consumption, discussed below.

2.3 Gripper: MEMS SOI 15 mN Gripper

The $14.5 \times 9.5 \times 0.6 \text{ mm}^3$ MEMS gripper used in SARA is a later iteration of the design by Schindler et al. [25]. The gripper is microfabricated in a three mask silicon-on-insulator process with a $40 \mu\text{m}$ thick device layer, and in this silicon device layer is an electrostatic inchworm motor—using the motor architecture proposed in [19]—which linearly actuates the gripper jaw up to 3 mm when suitably powered. The motor consists of a shuttle and two arrays of gap closing actuator finger pairs (with 1536 finger pairs per array). Each of these arrays is a capacitive transducer connected to ground and one high voltage ($>40 \text{ V}$) input signal. The input signals are generated by the SC μ M chip and buffered to high voltage by Zappy2. When an input signal is raised to a high voltage, the corresponding array charges, closing its finger pairs, and via a compliant mechanical linkage pushes the shuttle forward

2 μm then holds it in place. If the second array is then charged and the first is released, the shuttle moves an additional 2 μm . Driving the two arrays with $>50\%$ duty cycle square waves 180 degrees out of phase creates continuous movement. When both arrays are discharged simultaneously, the shuttle is free to move and is retracted by a silicon serpentine spring; this is how the gripper jaw returns to its original position.

As with stepper motors, since the motor moves a fixed distance every input signal period, its actuation speed is proportional to the input signal frequency f [19]. In this implementation with $d = 2 \mu\text{m}/\text{step}$ and $n = 2$ steps/period, the motor moves at speed $n \cdot d \cdot f$: 1 mm s^{-1} at 250 Hz or 4 $\mu\text{m s}^{-1}$ at 1 Hz. This gripper has been successfully actuated at speeds up to 1 mm s^{-1} with an external power supply (likely limited by excessive friction in the integrated system) [25]. Experimental tests of the same motor architecture have demonstrated 35 mm s^{-1} movement [7].

Each of the two capacitive transducer arrays has approximately 40 pF maximum (closed) capacitance (and a parasitic 30 pF in parallel for total capacitance $C \approx 70\text{pF}$). When its input signal is raised high, the array charges with energy $\frac{1}{2}CV^2$ and puts an additional $\frac{1}{2}CV^2$ toward mechanical work and heat. When the signal is returned to ground the stored capacitive energy is lost. Thus the power draw of the entire motor on the drive electronics is approximately $2 \cdot \frac{1}{2}CV^2 \cdot n \cdot f$, e.g., 0.35 mW at 1 mm s^{-1} and 100 V, or 56 μW at 1 mm s^{-1} and 40 V. Note that at zero speed, i.e., holding position without movement, the motor theoretically draws negligible power. In reality, leakage current due to parasitics, especially parallel resistance when the array fingers are closed, can dominate; we explore this in later sections (see Figure 3.5). The advantage of higher voltage is that the motor force is proportional to voltage squared: this motor, after inefficiencies, provides up to 15 mN at 100 V or 2.4 mN at 40 V [25]. Motor efficiency as defined by [19] is $\eta \approx 15\text{mN} \cdot 2\mu\text{m} / \frac{1}{2}CV^2 \approx 9\%$ (and parasitics—see Figure 3.5—reduce this further). This could be increased significantly by using a variable-voltage driving waveform to reduce both nonlinearities in the capacitive transducer and RC charging losses [19, 16].

Chapter 3

System Operation

The integrated SARA microsystem operates in 5 phases indicated in Figure 1.2 and detailed in this section.

3.1 Phase 1: Optical Calibration

A Teensy 3.6 microcontroller with an IR LED is used to send signals to the optical receiver on SC μ M in order to bootload a program [32]. After programming, SC μ M enters an optical calibration phase. This calibration is needed to calibrate the CMOS oscillators on SC μ M since the chip lacks a crystal reference. The same IR programmer sends 20 pulses of an optical signal at 10 Hz to trigger optical interrupts on SC μ M [32]. Upon receiving an interrupt, SC μ M uses the time between interrupts as an absolute reference for calibrating its oscillators. The calibrated clocks include a 20 MHz HF CPU clock, a 2 MHz RC chipping clock, and an IF radio clock.

During bootup, SC μ M has the following VBAT current transient: 300 μ A unprogrammed/idle, 350 μ A for 0.5 s while programming and initializing, 1.6 mA optical calibration for 2 s, and lastly idle at 350 μ A. The 1.6 mA exceeds the 560 μ A provided by the solar cells at 200 mW/cm². Thus, while calibrating, SC μ M is connected to an external 1.7 V VBAT. Additionally, an external 3.3 V VDDIO source is connected during calibration to ensure that the Zappy2 FSM is properly initialized.

3.2 Phase 2: Solar Power and LC Calibration

Once calibrated, the external 1.7 V and 3.3 V power sources are disconnected and SC μ M operates autonomously on solar power from Zappy2. Under 200 mW/cm² irradiation (2 suns) provided by a fiber optic light illuminator, the solar cells provide 560 μ A at 1.86 V. This provides power to operate SC μ M at a reduced 78 kHz clock rate ($I_{\text{VBAT}}=200 \mu\text{A}$) between periods of full speed operation at 5 MHz ($I_{\text{VBAT}}=350 \mu\text{A}$). The 2 suns illumination was chosen as the 560 μ A current provided exceeds the $I_{\text{VBAT}}=350 \mu\text{A}$ idle current. Additionally, it

provides enough current along with the 100 μF VBAT capacitor to operate SC μM with radio-on $I_{\text{VBAT}}=1.6\text{ mA}$ for $\sim 2\text{ ms}$ periods while still maintaining 802.15.4 standard compatibility. Further justification is provided in section 3.3.

Additional calibration is required to set the radio local oscillator frequency to properly transmit 802.15.4 packets at 2.405 GHz for channel 11 as well as receive packets at 2.410 GHz on 802.15.4 channel 12. This additional calibration is needed as the optical programming phase is not able to accurately calibrate the local oscillator. This occurs because when calibrating the local oscillator the divider chain is required to be turned on which increases the current consumption from 1.6 mA to more than 2 mA. Attempts to turn the divider chain off after calibration resulted in the local oscillator shifting it's frequency. Thus, to calibrate, SC μM sweeps across tuning settings with the divider chain off for each of the three 5-bit capacitive DACs used to set the frequency for the LC local oscillator (coarse, mid, and fine settings). The LC codes are swept until a packet is properly transmitted on channel 11 to an RX OpenMote. Next, the LC codes are again swept until SC μM properly receives a packet on channel 12 from an TX OpenMote (Figure 1.2). The TX and RX LC configuration codes are then fixed and SC μM is now properly calibrated to transmit and receive on those specific channels.

The LC is calibrated with the goal of maintaining 802.15.4 standard compatibility. This standard defines a $\pm 40\text{ ppm}$ maximum local oscillator frequency error which is difficult to achieve without a crystal reference. This is especially challenging in an energy-constrained and solar-powered system due to large voltage drops across the 100 μF VBAT capacitor that occur during radio operation which shift the frequencies of the CMOS oscillators (see section 3.3).

Furthermore, this calibration is complicated by the 160 ppm/ $^{\circ}\text{C}$ [33] and $-40\text{ ppm}/^{\circ}\text{C}$ [17] temperature dependence of the 2 MHz radio chipping clock and 2.4 GHz radio local oscillator, respectively.

In prior work, SC μM and Zappy2 have been integrated into a wireless temperature sensing node featuring temperature based LC compensation across a temperature range of 35.5 $^{\circ}\text{C}$ to 40.0 $^{\circ}\text{C}$ [18]. For this integration the LC codes are fixed as previously described rather than continuously calibrated. Future work could integrate this continuous LC calibration into the SARA robot.

3.3 Phase 3: Receive Packets

While operating, the radio is enabled for 1 ms to attempt to receive an 802.15.4 packet from a TX OpenMote (Figure 1.2). This requires 1.6 μC of charge for $I_{\text{radio.on}}=1.6\text{ mA}$. The transient current of SC μM during radio operation under solar power can be seen in Figure 3.2. The 1 ms radio on period was chosen to minimize voltage drop on VBAT while the radio is on. The TX OpenMote is continuously transmitting 6 byte packets with a command to actuate the gripper. Phase $\phi 3$ is repeated approximately every second until a command is received. The time in between repetitive Phase $\phi 3$ s could be reduced.

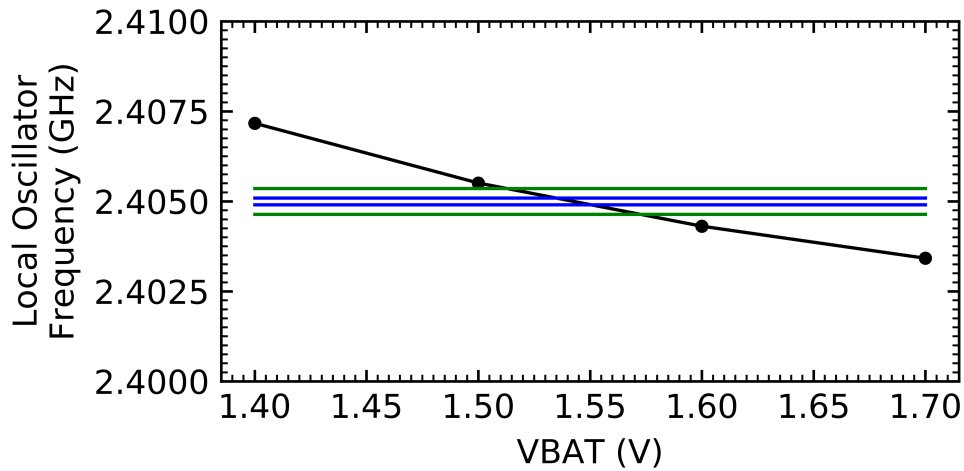

Figure 3.1: Crystal-free radio local oscillator frequency vs. VBAT voltage at a fixed LC tuning setting. The blue lines shows the ± 40 ppm tolerance band of the 802.15.4 standard and the green lines shows the ± 150 ppm tolerance of the OpenMote.

With the solar cell array under 200 mW/cm^2 irradiation and the $100 \mu\text{F}$ bypass capacitor across VBATPV, SC μM receives $560 \mu\text{A}$ at 1.86 V . This can power SC μM at $I_{\text{radio_on}}$ of 1.6 mA for 25 ms before VBAT drops from 1.86 V to the operating minimum of 1.3 V . Additionally, SC μM has been shown to send and receive packets under solar with a $20 \mu\text{F}$ capacitor which can keep the radio on for 11 ms .

In practice, however, such a large voltage drop across VBAT shifts the local oscillator frequency and prevents proper radio operation (Figure 3.1). The slope of the LO frequency vs. VBAT curve (Figure 3.1) at $\text{VBAT}=1.8 \text{ V}$ is approximately 5 MHz V^{-1} . To maintain ± 40 ppm stability ($\pm 100 \text{ kHz}$), the VBAT supply must be stable to less than $\pm 20 \text{ mV}$ variation. A 20 mV VBAT drop limit permits the radio to be enabled for at most 1.92 ms to maintain standards compatibility.

Specifically, based on the frequency shift from 2.4028 GHz at $I_{\text{VBAT}}=1.8 \text{ V}$ to 2.4023 GHz at $I_{\text{VBAT}}=1.9 \text{ V}$ (Figure 3.1), the VBAT voltage on SC μM must shift at most $\pm 20 \text{ mV}$ during a period of radio operation to ensure the frequency stays within the ± 40 ppm frequency tolerance.

3.4 Phase 4: Transmit acknowledgement

After receiving a command to close the gripper, SC μM enables its radio for 4 ms to transmit a 10 byte packet to an OpenMote to confirm that the command was received. The current consumption during the 4 ms transmission period is presented in Figure 3.4. It should be noted that the transmitter should theoretically take closer to 0.4 ms to transmit a 10 byte packet. However, in practice the packet received by the OpenMote would be corrupt if the

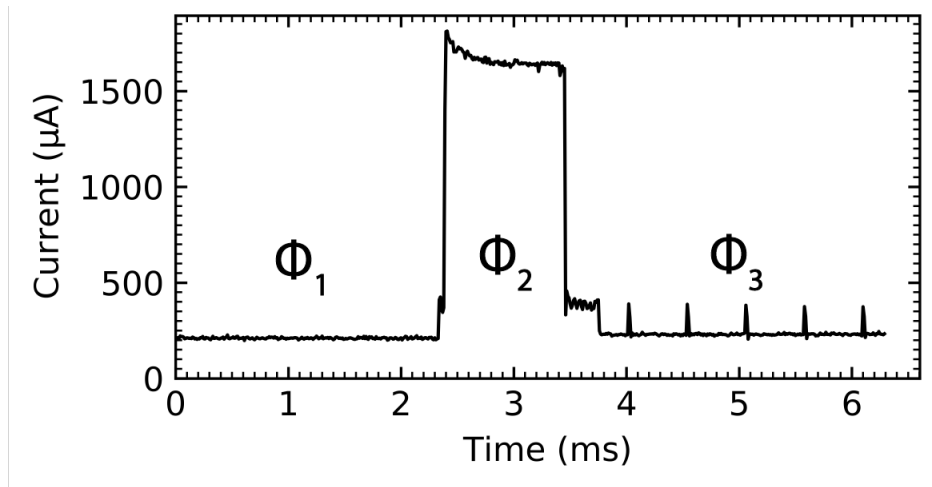

Figure 3.2: VBAT current during wireless 802.15.4 receive (200 mW/cm^2 irradiation; $47 \mu\text{F}$ VBAT bypass capacitor). ϕ_1 : Low power ($F_{\text{cortex}}=78 \text{ kHz}$), ϕ_2 : RX with radio on, ϕ_3 : periodic wake up to $F_{\text{cortex}}=5 \text{ MHz}$

radio-on time was reduced too much. Transmitting packets is difficult due to high radio-on current draw which causes a drop in VBAT voltage as charge is pulled from the $100 \mu\text{F}$ VBAT bypass capacitor. The challenges of maintaining the proper local oscillator frequency are similar to those described in section 3.3, but now the radio is on for a longer period of time (4 ms TX vs. 1 ms RX). Despite this increased radio on period, SC μ M was able to properly send packets as the transmission completes within the first 1 ms (corresponds to $\sim 40 \text{ mV}$ VBAT drop; see Figure 3.3). Further development has decreased the total radio on time to 1 ms. The OpenMote device used for these tests has a higher $\pm 150 \text{ ppm}$ frequency tolerance [33] over the $\pm 40 \text{ ppm}$ tolerance in the 802.15.4 standard. This increased tolerance was leveraged to help receive packets from SC μ M.

3.5 Phase 5: MEMS Gripper Actuation

After sending the acknowledgement that the command to close the gripper was received, SC μ M begins sending three control signals through GPIO pins 1, 4, and 5 (powered by VDDIOPV) to Zappy2 (Figure 1.2). The GPIO output specifications can be seen in Table 3.1. The first signal originates from the SC μ M 500 kHz RF timer and is passed through GPIO 1 (Figure 1.2) as the CLK_{HV} clock source for the Zappy2 digital state machine. GPIO pins 4 and 5 are fed into two of the four high voltage (HV) buffers on Zappy2, which in turn connect the gripper to the Zappy2 VDDHPV HV source. Toggling these pins from 0 V to 3.5 V (with a 60% duty cycle) and 180 degrees out of phase with each other actuates the electrostatic inchworm motor of the gripper as described in section 2.3.

The current provided by the VDDHPV source on the solar cell and the current consump-

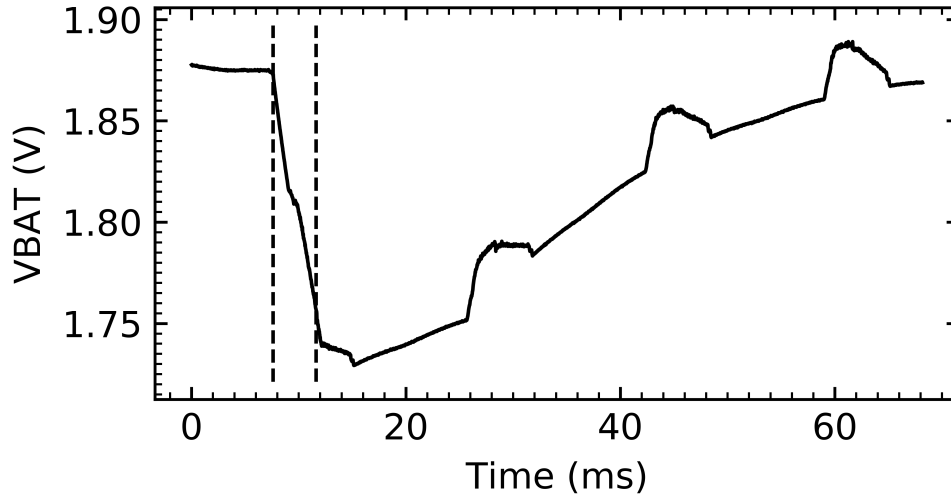

Figure 3.3: VBAT voltage vs. time during wireless 802.15.4 transmit (200 mW/cm^2 irradiation; $100 \mu\text{F}$ bypass capacitor). The dashed lines indicate the 4 ms period when the radio was enabled.

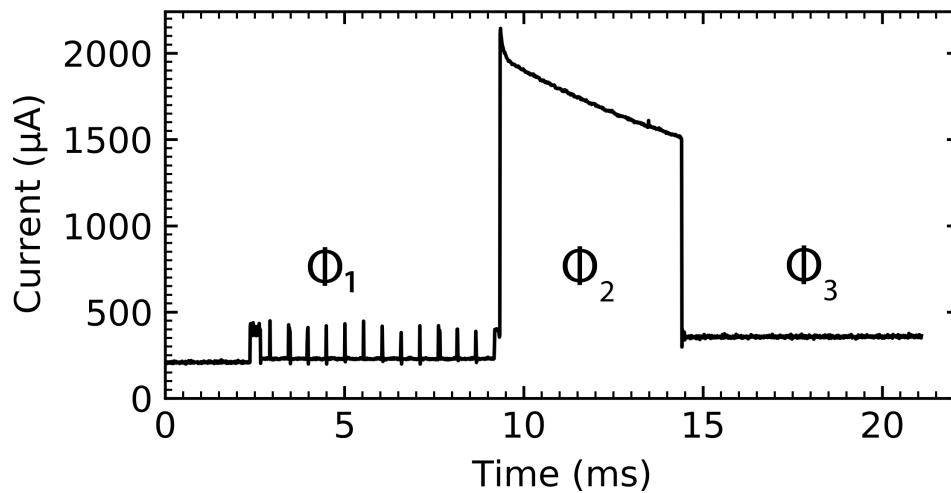

Figure 3.4: VBAT current during wireless 802.15.4 transmit (200 mW/cm^2 irradiation; $20 \mu\text{F}$ bypass capacitor). Phases: ϕ_1 : $F_{\text{cortex}}=78 \text{ kHz}$ low power mode and UART logging before transmit, ϕ_2 : Transmit 10 byte packet, ϕ_3 : $F_{\text{cortex}}=5 \text{ MHz}$ idle state

Table 3.1: GPIO_{output} Specifications

Specification	Value
VDDIO	0.8-3.6 V
VDDAUX	0.8-1.2 V
F_{\max} @ HCLK = 10 MHz	734.25 KHz
$I_{\text{VDDIOleakage}}$ @ VDDIO = 3.3 V	4.37 nA
$I_{\text{sink/source}}$ @ VDDIO = 3.3 V	19 mA

tion of the gripper while held at a DC voltage can be seen in Figure 3.5. The GPIO signals and the corresponding buffered HV signals used for gripper actuation can be seen in Figure 3.6.

We can use Figure 3.5 to determine the maximum speed operating points of the gripper. Because the gripper is capacitive, its speed, as in section 2.3, is determined solely by its driving frequency while it charges to the maximum voltage (and thus force) available. At fast speeds, however, insufficient power is supplied to charge the gripper each signal period so the voltage across its capacitance decreases. Once the voltage falls below the minimum 40 V, the gripper fails to move. In this implementation, however, the gripper also has non-negligible leakage current draw under DC input. This sets the minimum power draw of the gripper at a given voltage as its speed approaches zero and duty cycle approaches 100%.

Thus, under 200 mW/cm² irradiation, the operating point of the HV buffers and the gripper (for slow speeds and high duty cycles) is ~4.75 μA at ~59 V (Figure 3.5). According to section 2.3, at this voltage, the force of the gripper is approximately 5.2 mN. If we assume the leakage current graphed in Figure 3.5 only appears across the gripper when a motor array is charged (i.e., the gap closing actuators are closed, which makes sense if their fingers are touching and causing a high-resistance short), then the proportion remaining power available to actuate the gripper is 1 minus the duty cycle (here, 60%), for $4.75\mu\text{A}\cdot 59\text{V}\cdot 0.4 = 0.11\text{mW}$, which is sufficient for up to 920 $\mu\text{m s}^{-1}$ speed. While testing the integrated SARA system at 200 mW/cm² irradiation, GPIO toggling speeds up to 160 Hz resulted in movement, corresponding to a maximum speed of 640 $\mu\text{m s}^{-1}$ closing the full 3 mm distance under solar power in ~4.7 s (the slower-than-theoretical maximum achievable speed implies some of the gripper leakage is always present, reducing power available for movement, and friction may also play a role).

Each of the three Zappy2 voltage domains (VBATPV, VDDIOPV, and VDDHPV) must maintain a minimum voltage during actuation of the MEMS gripper. During gripper actuation, SC μM operates at a $F_{\text{cortex}}=78\text{kHz}$ with $I_{\text{VBAT}}=200\mu\text{A}$. This is within the 560 μA provided by the VBATPV supply. The $I_{\text{VDDIO}}=1\mu\text{A}$ consumed while toggling the GPIO pins at 160 Hz is well under the ~32 μA provided by the VDDIOPV source. Lastly, the VDDHPV current while toggling and actuating the gripper is on average ~4.75 μA , smoothed by a 100 nF capacitor.

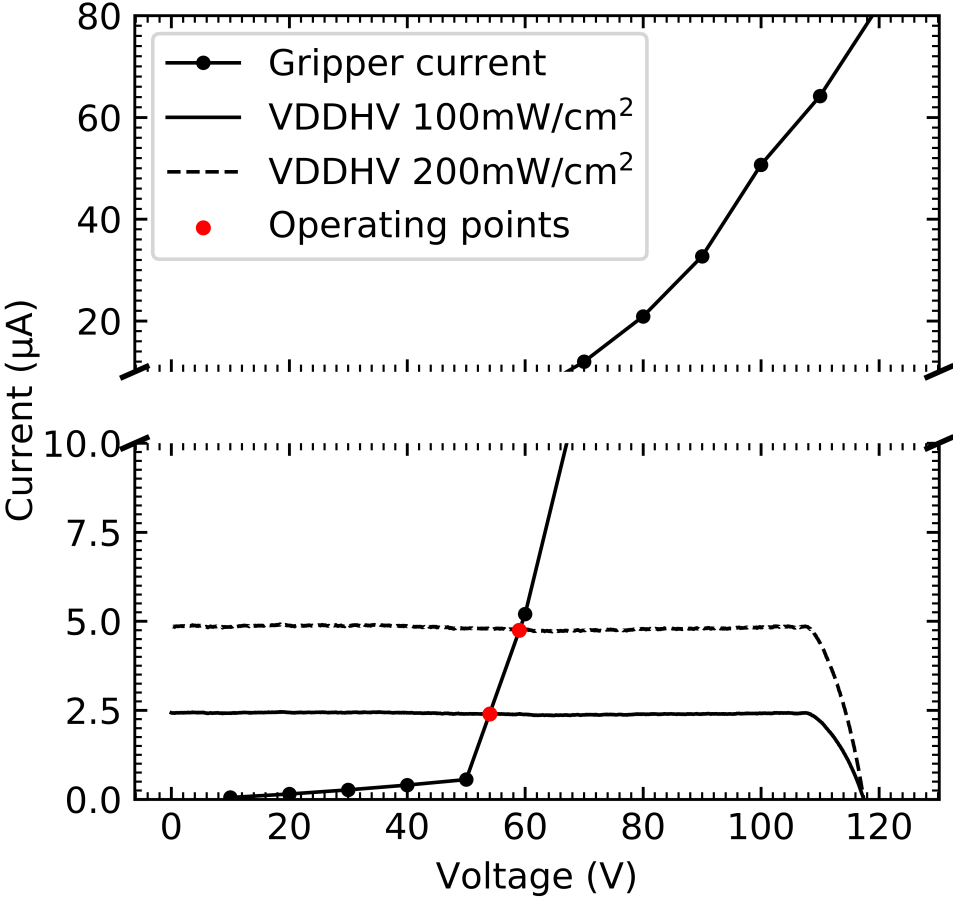

Figure 3.5: Measured gripper leakage current under DC supply vs. HV buffer DC voltage, and Zappy2 VDDHPV supply current vs. VDDHPV voltage under 100 mW/cm² (measured) and 200 mW/cm² irradiation (estimated). Red intersections represent operating points of the system at 100 mW/cm² and 200 mW/cm² irradiation while closing the gripper at very slow speeds approaching zero and duty cycles approaching 100%.

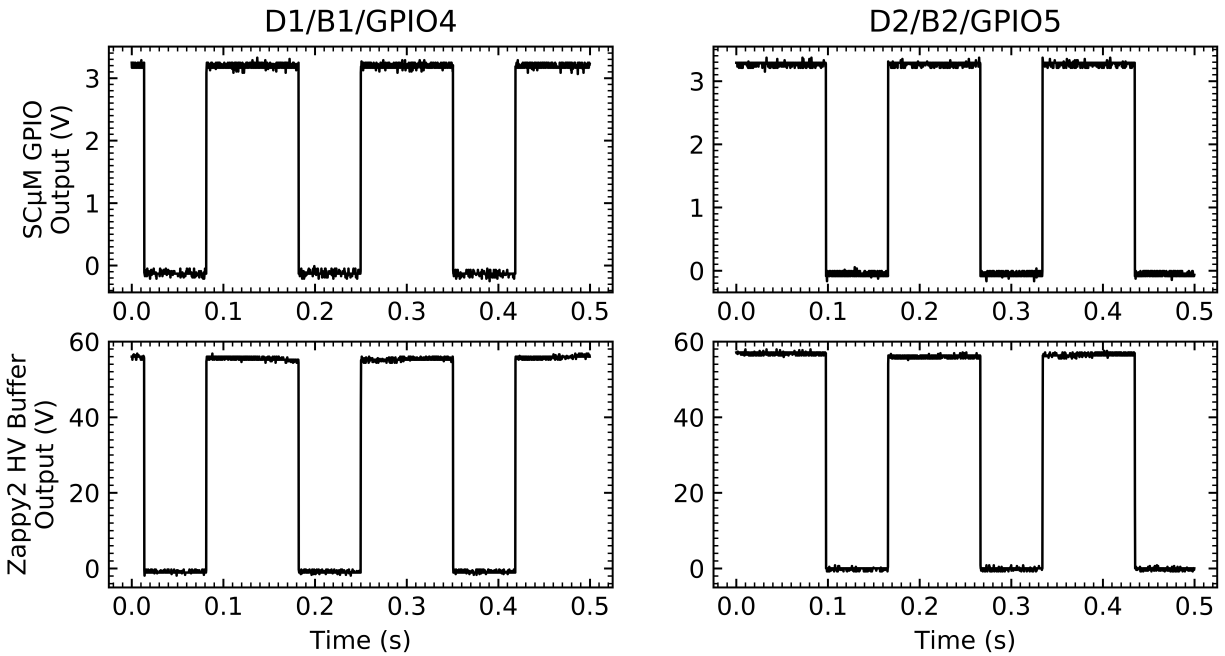

Figure 3.6: Toggling of HV buffers driving MEMS gripper at 200 mW/cm^2 irradiation. SC μ M GPIO pins 4 and 5 are enabling/disabling 59 V HV buffered outputs D1 and D2 (respectively) on Zappy2. GPIOs toggling at 5.9 Hz with a 60% duty cycle at a 180 degree phase offset from each other.

Finally, SC μ M returns to Phase ϕ_3 and begins listening for packets with "actuate gripper" commands. The gripper has been demonstrated to repeatedly open and close after multiple iterations of the receive-acknowledge-actuate loop.

Chapter 4

Conclusion

Under conditions of steady 200 mW/cm^2 irradiation on Zappy2 we have demonstrated full SARA system operation. This includes receiving a six byte wireless command to actuate the gripper from a standard 2.4 GHz 802.15.4 transmitter, transmitting a ten byte standards-compatible 802.15.4 packet as an acknowledgement, and autonomous microprocessor-controlled MEMS gripper actuation. The gripper has then been demonstrated to fully close at a rate of $640 \mu\text{m s}^{-1}$ to close the full 3 mm distance in roughly 4.7 s. After the gripper has closed the SARA system successfully repeated the entire receive-acknowledge-actuate procedure repeatedly without failure.

The integrated SARA microsystem with power, control, and mechanical elements provides capabilities that previously would not be possible. An autonomous MEMS gripper could be used in micro assembly and manufacturing systems that require manipulation at a μm scale. Feedback control could be obtained by using the contact sensor on the MEMS gripper which could enable a μm scale caliper device to make size measurements of objects. Further developments will allow the integration of new jumping [24], walking [6], and fiber crawling [36] MEMS devices. For example, a MEMS inchworm motor could pull the SARA microsystem along a cord strung across an interior space to use SC μ M as an autonomous, battery-free sensor. Multiple devices with SC μ M and MEMS chips integrated could also be used in mesh networking systems for micro-scale robotic exploration.

Bibliography

- [1] Colby L Bellew, Seth Hollar, and KSJ Pister. “An SOI process for fabrication of solar cells, transistors and electrostatic actuators”. In: *TRANSDUCERS’03. 12th International Conference on Solid-State Sensors, Actuators and Microsystems. Digest of Technical Papers (Cat. No. 03TH8664)*. Vol. 2. IEEE. 2003, pp. 1075–1078.
- [2] Gilles Caprari and Roland Siegart. “Mobile micro-robots ready to use: Alice”. In: *2005 IEEE/RSJ international conference on intelligent robots and systems*. IEEE. 2005, pp. 3295–3300.
- [3] T. Chang et al. “QuickCal: Assisted Calibration for Crystal-Free Micromotes”. In: *IEEE Internet of Things Journal* 8.3 (2021), pp. 1846–1858. DOI: 10.1109/JIOT.2020.3015725.
- [4] Tengfei Chang et al. “6TiSCH on SCμM: Running a Synchronized Protocol Stack without Crystals”. In: *ACM Embedded Wireless Systems and Networks*. 2020.
- [5] Wayne Churaman et al. “The First Launch of an Autonomous Thrust-Driven Microrobot Using Nanoporous Energetic Silicon”. In: *Microelectromechanical Systems, Journal of* 21 (Feb. 2012), pp. 198–205. DOI: 10.1109/JMEMS.2011.2174414.
- [6] D. S. Contreras, D. S. Drew, and K. S. J. Pister. “First steps of a millimeter-scale walking silicon robot”. In: *2017 19th International Conference on Solid-State Sensors, Actuators and Microsystems (TRANSDUCERS)*. 2017, pp. 910–913. DOI: 10.1109/TRANSDUCERS.2017.7994197.
- [7] D. S. Contreras and K. S. J. Pister. “Dynamics of electrostatic inchworm motors for silicon microrobots”. In: *2017 International Conference on Manipulation, Automation and Robotics at Small Scales (MARSS)*. July 2017, pp. 1–6. DOI: 10.1109/MARSS.2017.8001936.
- [8] Daniel S. Contreras and K.S.J. Pister. “A Six-Legged MEMS Silicon Robot Using Multichip Assembly”. In: *Solid State Sensors and Actuators Workshop, Hilton Head*. 2018.
- [9] Nikolaus Correll, Samuel Rutishauser, and Alcherio Martinoli. “Comparing coordination schemes for miniature robotic swarms: A case study in boundary coverage of regular structures”. In: *Experimental Robotics*. Springer. 2008, pp. 471–480.

- [10] Daniel S Drew et al. “Toward controlled flight of the ionocraft: a flying microrobot using electrohydrodynamic thrust with onboard sensing and no moving parts”. In: *IEEE Robotics and Automation Letters* 3.4 (2018), pp. 2807–2813.
- [11] S. Hollar et al. “Solar powered 10 mg silicon robot”. In: *The Sixteenth Annual International Conference on Micro Electro Mechanical Systems, 2003. MEMS-03 Kyoto. IEEE*. 2003, pp. 706–711. DOI: 10.1109/MEMSYS.2003.1189847.
- [12] Allen Hsu et al. “Application of micro-robots for building carbon fiber trusses”. In: *2016 international conference on manipulation, automation and robotics at small scales (MARSS)*. IEEE. 2016, pp. 1–6.
- [13] Vikram Iyer et al. “Wireless steerable vision for live insects and insect-scale robots”. In: *Science robotics* 5.44 (2020).
- [14] Noah Jafferis et al. “Untethered flight of an insect-sized flapping-wing microscale aerial vehicle”. In: *Nature* 570 (June 2019), pp. 491–495. DOI: 10.1038/s41586-019-1322-0.
- [15] J. James et al. “Liftoff of a 190 mg Laser-Powered Aerial Vehicle: The Lightest Wireless Robot to Fly”. In: *2018 IEEE International Conference on Robotics and Automation (ICRA)*. 2018, pp. 3587–3594. DOI: 10.1109/ICRA.2018.8460582.
- [16] Yanqiao Li, Benjamin L Dobbins, and Jason T Stauth. “An Optically Powered, High-Voltage, Switched-Capacitor Drive Circuit for Microrobotics”. In: *IEEE Journal of Solid-State Circuits* (2020).
- [17] Filip Maksimovic et al. “A Crystal-Free Single-Chip Micro Mote with Integrated 802.15.4 Compatible Transceiver, sub-mW BLE Compatible Beacon Transmitter, and Cortex M0”. In: *VLSI 2019*. IEEE. 2019.
- [18] Alex Moreno et al. “Solar-Powered Crystal-Free 802.15.4 Wireless Temperature Sensor”. In: *2020 IEEE Sensors*. IEEE. 2020, pp. 1–4.
- [19] I. Penskiy and S. Bergbreiter. “Optimized electrostatic inchworm motors using a flexible driving arm”. en. In: *Journal of Micromechanics and Microengineering* 23.1 (Dec. 2012). Publisher: IOP Publishing, p. 015018. ISSN: 0960-1317. DOI: 10.1088/0960-1317/23/1/015018. (Visited on 10/12/2020).
- [20] Jan S. Rentmeister et al. “A 120-330V, sub- μ A, 4-Channel Driver for Microrobotic Actuators with Wireless- Optical Power Delivery and over 99% Current Efficiency”. In: *2020 IEEE Symposium on VLSI Circuits*. Honolulu, HI, USA, 2020.
- [21] Michael Rubenstein et al. “Kilobot: A low cost robot with scalable operations designed for collective behaviors”. In: *Robotics and Autonomous Systems* 62.7 (2014), pp. 966–975.
- [22] Andrew P Sabelhaus et al. “TinyTeRP: A tiny terrestrial robotic platform with modular sensing”. In: *2013 IEEE International Conference on Robotics and Automation*. IEEE. 2013, pp. 2600–2605.

- [23] Ken Saito et al. “Study on electrostatic inchworm motor device for a heterogeneous integrated microrobot system”. In: *Transactions of The Japan Institute of Electronics Packaging* 12 (2019), E18–009.
- [24] C. B. Schindler et al. “A Jumping Silicon Microrobot with Electrostatic Inchworm Motors and Energy Storing Substrate Springs”. In: *2019 20th International Conference on Solid-State Sensors, Actuators and Microsystems Eurosensors XXXIII (TRANSDUCERS EUROSENSORS XXXIII)*. 2019, pp. 88–91. DOI: 10.1109/TRANSDUCERS.2019.8808463.
- [25] Craig Schindler et al. “15 Millinewton Force, 1 Millimeter Displacement, Low-Power MEMS Gripper”. In: *IEEE MEMS*. 2020.
- [26] Craig B Schindler et al. “A jumping silicon microrobot with electrostatic inchworm motors and energy storing substrate springs”. In: *2019 20th International Conference on Solid-State Sensors, Actuators and Microsystems & Eurosensors XXXIII (TRANSDUCERS & EUROSENSORS XXXIII)*. IEEE. 2019, pp. 88–91.
- [27] Metin Sitti et al. “Biomedical applications of untethered mobile milli/microrobots”. In: *Proceedings of the IEEE* 103.2 (2015), pp. 205–224.
- [28] Ioana Suciu et al. “Dynamic Channel Calibration on a Crystal-Free Mote-on-a-Chip”. In: *IEEE Access* 7 (2019), pp. 120884–120900.
- [29] Ioana Suciu et al. “Experimental clock calibration on a crystal-free mote-on-a-chip”. In: *IEEE INFOCOM 2019-IEEE Conference on Computer Communications Workshops (INFOCOM WKSHPS)*. IEEE. 2019, pp. 608–613.
- [30] Xavier Vilajosana et al. “OpenMote: Open-Source Prototyping Platform for the Industrial IoT”. In: *International Conference on Ad Hoc Networks (AdHocNets)*. San Remo, Italy, Sept. 2015, pp. 211–222. DOI: 10.1007/978-3-319-25067-0_17.
- [31] Thomas Watteyne et al. “OpenWSN: a standards-based low-power wireless development environment”. In: *Transactions on Emerging Telecommunications Technologies* 23.5 (2012), pp. 480–493.
- [32] Brad Wheeler et al. “A Low-Power Optical Receiver for Contact-free Programming and 3D Localization of Autonomous Microsystems”. In: *IEEE UEMCON*. 2019.
- [33] Bradley Wheeler. “Low Power, Crystal-Free Design for Monolithic Receivers”. PhD thesis. EECS Department, University of California, Berkeley, May 2019.
- [34] T. Yuan et al. “Temperature Calibration on a Crystal-Free Mote”. In: *2020 IEEE 6th World Forum on Internet of Things (WF-IoT)*. 2020, pp. 1–5. DOI: 10.1109/WF-IoT48130.2020.9221351.
- [35] Xuan Zhang et al. “A fully integrated battery-powered system-on-chip in 40-nm CMOS for closed-loop control of insect-scale pico-aerial vehicle”. In: *IEEE Journal of Solid-State Circuits* 52.9 (2017), pp. 2374–2387.

- [36] R. S. Zoll et al. “MEMS-Actuated Carbon Fiber Microelectrode for Neural Recording”. In: *IEEE Transactions on NanoBioscience* 18.2 (2019), pp. 234–239. DOI: 10.1109/TNB.2019.2905505.