

# EE140: Lab 3 Part 1

## 2 stage bipolar op-amp

### Instruction

For this lab, you may consult the professor, the TAs, your friends, the textbook, the internet, and any other living or inanimate objects, with the exception of your peers' lab reports. You may obtain data in pairs, but must **submit your own written report**. Be concise. Hand calculations should be to 1 or at most 2 digits of precision. Don't use a calculator – I won't let you use one on the exam and it's good to get in practice.

### Objective

This lab is meant to familiarize you with 2-stage op-amps, and in particular unity-gain feedback.

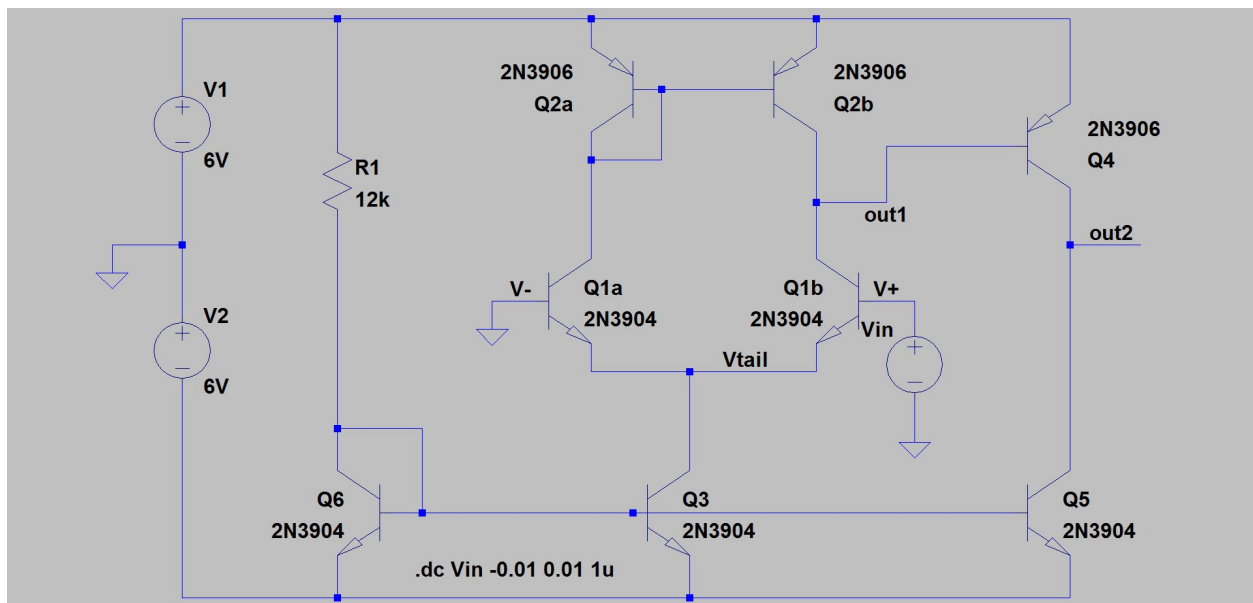

Figure 1: Lab 2 Op-Amp [File: BJTopamp.asc]

SPICE model parameters. You can see the parameters that LTSPICE uses by right clicking on an element and selecting “Choose new device”. The parameters that you need for your hand analysis are:

2N3904 NPN (VAF=100 Bf=300 CJC=4p CJE=8p)

2N3906 PNP (VAF=100 Bf=200 CJC=5p CJE=10p)

### Prelab – Hand analysis and SPICE

1. [Writeup] Hand calculate, for  $V_{in}=0$ , the following values. 1 sig-fig is fine (i.e.,  $I_{C6}=1\text{mA}$  is close enough)
  - a. All bias currents and bias voltages. Make a table with columns for transistors and rows for the various parameters.
  - b.  $g_m$  and  $r_o$  for all devices, and  $r_{\pi 4} = \beta/g_{m4}$  for Q4

- c. The DC gain from  $V_{in}$  to out1 **without** the 2<sup>nd</sup> stage connected.
  - d. The DC gain from  $V_{in}$  to out1 **with** the 2<sup>nd</sup> stage connected. This is one case where we see an important difference between bipolar and MOS. The small signal input resistance of Q4,  $r_{\pi 4} = \beta/g_{m4}$ , is the smallest resistance at node out1, and substantially lowers the DC gain of the first stage.
  - e. The DC gain from out1 to out2, and from  $V_{in}$  to out2.
2. Use LTspice on the file BJTtopamp.asc to run a DC sweep on the amplifier in Figure 1.
    - a. Click on the out1 wire. Find the highest gain from  $V_{in}$  to out1.
    - b. Click on the out2 wire. Find the highest gain from  $V_{in}$  to out2, and over that same region of highest gain, find the gain from  $V_{in}$  to out1.
    - c. [Writeup] Compare your hand calculated gains to the gains that you simulated in 2a and 2b.
  3. Calculate the closed loop gain error if this amplifier is used in the feedback configuration shown in Figure 2.
    - a. Open BJTtopamp101xFB.asc in LTspice and run it. The input to the amplifier is a 1mV step.
    - b. [Writeup] What voltage does the output settle to? Compare the gain to the value you calculated.

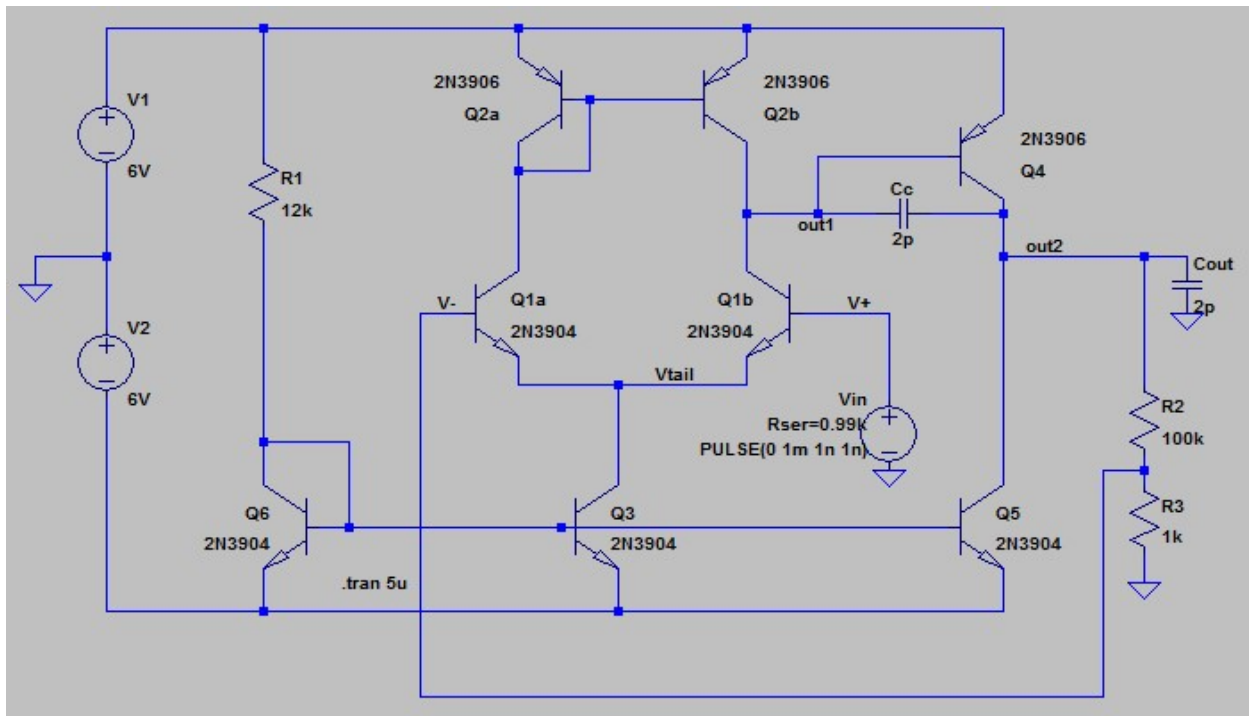
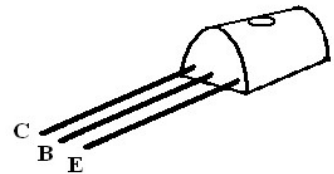

Figure 2: The op-amp in resistive feedback. Capacitors  $C_c$  and  $C_{out}$  represent typical parasitics for a breadboard. (Note that I changed  $V_{in}$  to have a source resistance of 0.99k to match the feedback network, to avoid the effect of input bias current. Not necessary in CMOS.)  
 [File: BJTtopamp101xFB.asc]

## Lab



- 1) Build the circuit in *Figure 1*.
  - a. You should plan your entire breadboard layout before you ever place the first transistor!
  - b. Keep distances short, trim wires to fit, and connect all of your grounds to the same spot.
  - c. A neat breadboard layout is important to get this lab to work. It may seem like more effort up front, but it will save you time in the long run. The GSI can't help you debug if your circuit is a complete mess.
  - d. DO NOT TEAR APART YOUR CIRCUIT AT THE END. We will be using this circuit again for the next lab.
  
- 2) Measurements
  - a. DC Biases
    - i. Ground  $V_{in}$  and measure the tail voltage, the base voltage of Q6, and the base voltage of the Q2 mirror. Make sure that they are consistent with your hand calculations, and simulations.
  - b. Keep the negative input grounded, and sweep the positive input near 0V. Measure the gain from  $V_{in}$  to out1 and from  $V_{in}$  to out2. (Hint: if your input is a slow ramp, and you know the rate of change, can you use that to figure out the gain?) Verify that out2 swings nearly rail to rail.
    - i. Save the  $V_{in}$ , out1, and out2 waveforms and include them in your report. Either use a USB drive or Benchview on the computers to save the data.
    - ii. Compare to the spice plot and comment on any differences.
    - iii. Show your gain numbers to the GSI.
  
- 3) Put your amplifier in resistive feedback as shown in Figure 2.
  - a. Measure the gain and compare to your hand calculations and spice.
  - b. How much can you reduce the closed loop gain before you begin to see oscillatory behavior on the output?
  - c. Remember to keep your circuit intact for next week when we will further investigate the source of this instability.