

CS162 Operating Systems and Systems Programming Lecture 10

Deadlock (cont'd) Thread Scheduling

October 2, 2006
Prof. John Kubiatowicz
<http://inst.eecs.berkeley.edu/~cs162>

Review: Deadlock

- Starvation vs. Deadlock
 - Starvation: thread waits indefinitely
 - Deadlock: circular waiting for resources
 - Deadlock \Rightarrow Starvation, but not other way around
- Four conditions for deadlocks
 - **Mutual exclusion**
 - » Only one thread at a time can use a resource
 - **Hold and wait**
 - » Thread holding at least one resource is waiting to acquire additional resources held by other threads
 - **No preemption**
 - » Resources are released only voluntarily by the threads
 - **Circular wait**
 - » There exists a set $\{T_1, \dots, T_n\}$ of threads with a cyclic waiting pattern

10/2/06

Kubiatowicz CS162 ©UCB Fall 2006

Lec 10.2

Review: Resource Allocation Graph Examples

- Recall:
 - request edge - directed edge $T_i \rightarrow R_j$
 - assignment edge - directed edge $R_j \rightarrow T_i$

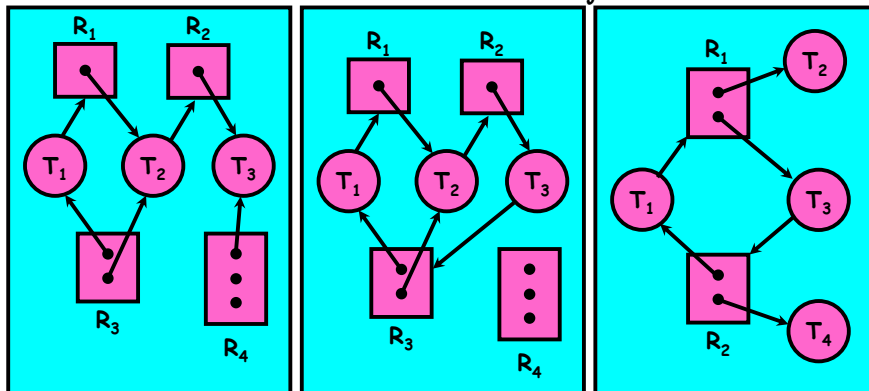

Simple Resource
Allocation Graph

Allocation Graph
With Deadlock

Allocation Graph
With Cycle, but
No Deadlock

10/2/06

Kubiatowicz CS162 ©UCB Fall 2006

Lec 10.3

Review: Methods for Handling Deadlocks



- Allow system to enter deadlock and then recover
 - Requires deadlock detection algorithm
 - Some technique for selectively preempting resources and/or terminating tasks
- Ensure that system will *never* enter a deadlock
 - Need to monitor all lock acquisitions
 - Selectively deny those that *might* lead to deadlock
- Ignore the problem and pretend that deadlocks never occur in the system
 - used by most operating systems, including UNIX

10/2/06

Kubiatowicz CS162 ©UCB Fall 2006

Lec 10.4

Goals for Today

- Preventing Deadlock
- Scheduling Policy goals
- Policy Options
- Implementation Considerations

Note: Some slides and/or pictures in the following are adapted from slides ©2005 Silberschatz, Galvin, and Gagne. Many slides generated from my lecture notes by Kubiawicz.

10/2/06

Kubiawicz CS162 @UCB Fall 2006

Lec 10.5

Deadlock Detection Algorithm

- Only one of each type of resource \Rightarrow look for loops
- More General Deadlock Detection Algorithm

- Let $[X]$ represent an m -ary vector of non-negative integers (quantities of resources of each type):

[FreeResources]: Current free resources each type
[Request_x]: Current requests from thread X
[Alloc_x]: Current resources held by thread X

- See if tasks can eventually terminate on their own

```
[Avail] = [FreeResources]
Add all nodes to UNFINISHED
do {
  done = true
  Foreach node in UNFINISHED {
    if ([Requestnode] <= [Avail]) {
      remove node from UNFINISHED
      [Avail] = [Avail] + [Allocnode]
      done = false
    }
  }
} until (done)
```

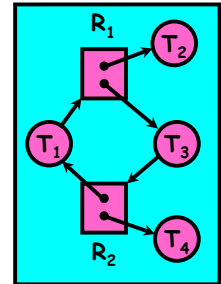

- Nodes left in UNFINISHED \Rightarrow deadlocked

10/2/06

Kubiawicz CS162 @UCB Fall 2006

Lec 10.6

What to do when detect deadlock?

- Terminate thread, force it to give up resources
 - In Bridge example, Godzilla picks up a car, hurls it into the river. Deadlock solved!
 - Shoot a dining lawyer
 - But, not always possible - killing a thread holding a mutex leaves world inconsistent
- Preempt resources without killing off thread
 - Take away resources from thread temporarily
 - Doesn't always fit with semantics of computation
- Roll back actions of deadlocked threads
 - Hit the rewind button on TiVo, pretend last few minutes never happened
 - For bridge example, make one car roll backwards (may require others behind him)
 - Common technique in databases (transactions)
 - Of course, if you restart in exactly the same way, may reenter deadlock once again
- Many operating systems use other options

10/2/06

Kubiawicz CS162 @UCB Fall 2006

Lec 10.7

Techniques for Preventing Deadlock

- Infinite resources
 - Include enough resources so that no one ever runs out of resources. Doesn't have to be infinite, just large
 - Give illusion of infinite resources (e.g. virtual memory)
 - Examples:
 - » Bay bridge with 12,000 lanes. Never wait!
 - » Infinite disk space (not realistic yet?)
- No Sharing of resources (totally independent threads)
 - Not very realistic
- Don't allow waiting
 - How the phone company avoids deadlock
 - » Call to your Mom in Toledo, works its way through the phone lines, but if blocked get busy signal.
 - Technique used in Ethernet/some multiprocessor nets
 - » Everyone speaks at once. On collision, back off and retry
 - Inefficient, since have to keep retrying
 - » Consider: driving to San Francisco; when hit traffic jam, suddenly you're transported back home and told to retry!

10/2/06

Kubiawicz CS162 @UCB Fall 2006

Lec 10.8

Techniques for Preventing Deadlock (con't)

- Make all threads request everything they'll need at the beginning.
 - Problem: Predicting future is hard, tend to over-estimate resources
 - Example:
 - » If need 2 chopsticks, request both at same time
 - » Don't leave home until we know no one is using any intersection between here and where you want to go; only one car on the Bay Bridge at a time
- Force all threads to request resources in a particular order preventing any cyclic use of resources
 - Thus, preventing deadlock
 - Example (x.P, y.P, z.P,...)
 - » Make tasks request disk, then memory, then...
 - » Keep from deadlock on freeways around SF by requiring everyone to go clockwise

10/2/06

Kubiatowicz CS162 ©UCB Fall 2006

Lec 10.9

Review: Train Example (Wormhole-Routed Network)

- Circular dependency (Deadlock!)
 - Each train wants to turn right
 - Blocked by other trains
 - Similar problem to multiprocessor networks
- Fix? Imagine grid extends in all four directions
 - Force ordering of channels (tracks)
 - » Protocol: Always go east-west first, then north-south
 - Called "dimension ordering" (X then Y)

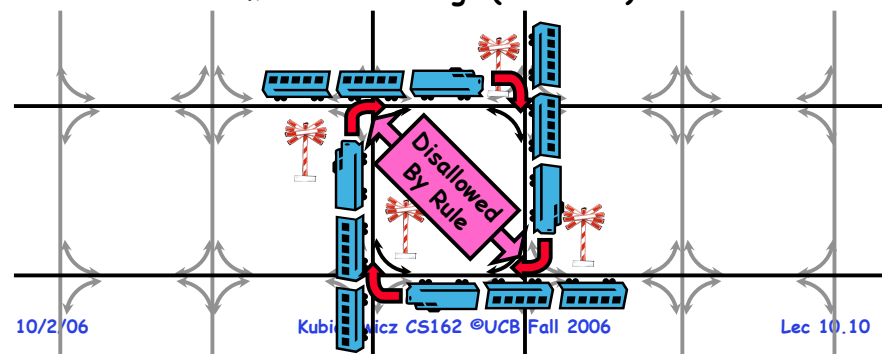

10/2/06

Kubiatowicz CS162 ©UCB Fall 2006

Lec 10.10

Banker's Algorithm for Preventing Deadlock

- Toward right idea:
 - State maximum resource needs in advance
 - Allow particular thread to proceed if:

$$(\text{available resources} - \# \text{requested}) \geq \max \text{ remaining that might be needed by any thread}$$
- Banker's algorithm (less conservative):
 - Allocate resources dynamically
 - » Evaluate each request and grant if some ordering of threads is still deadlock free afterward
 - » Technique: pretend each request is granted, then run deadlock detection algorithm, substituting $([\text{Max}_{\text{node}}] - [\text{Alloc}_{\text{node}}] \leq [\text{Avail}])$ for $([\text{Request}_{\text{node}}] \leq [\text{Avail}])$
Grant request if result is deadlock free (conservative!)
 - » Keeps system in a "SAFE" state, i.e. there exists a sequence $\{T_1, T_2, \dots, T_n\}$ with T_1 requesting all remaining resources, finishing, then T_2 requesting all remaining resources, etc..
 - Algorithm allows the sum of maximum resource needs of all current threads to be greater than total resources



10/2/06

Kubiatowicz CS162 ©UCB Fall 2006

Lec 10.11

Banker's Algorithm Example

- Banker's algorithm with dining lawyers
 - "Safe" (won't cause deadlock) if when try to grab chopstick either:
 - » Not last chopstick
 - » Is last chopstick but someone will have two afterwards
 - What if k-handed lawyers? Don't allow if:
 - » It's the last one, no one would have k
 - » It's 2nd to last, and no one would have k-1
 - » It's 3rd to last, and no one would have k-2
 - » ...



10/2/06

Kubiatowicz CS162 ©UCB Fall 2006

Lec 10.12

Administrivia

- Project 1 code due this Thursday (10/5)
 - Conserve your slip days!!!
 - It's not worth it yet.
- Group Participation: Required!
 - Group eval (with TA oversight) used in computing grades
 - Zero-sum game!
- Midterm I coming up in < two weeks:
 - Wednesday, 10/11, 5:30 - 8:30, Here
 - Should be 2 hour exam with extra time
 - Closed book, one page of hand-written notes (both sides)
- No class on day of Midterm
 - I will post extra office hours for people who have questions about the material (or life, whatever)
- Midterm Topics
 - Everything up to that Monday, 10/10
 - History, Concurrency, Multithreading, Synchronization, Protection/Address Spaces

10/2/06

Kubiatowicz CS162 @UCB Fall 2006

Lec 10.13

CPU Scheduling

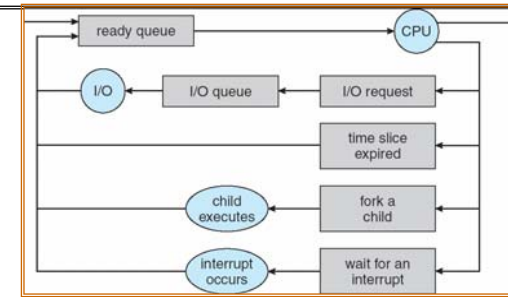

- Earlier, we talked about the life-cycle of a thread
 - Active threads work their way from Ready queue to Running to various waiting queues.
- Question: How is the OS to decide which of several tasks to take off a queue?
 - Obvious queue to worry about is ready queue
 - Others can be scheduled as well, however
- **Scheduling**: deciding which threads are given access to resources from moment to moment

10/2/06

Kubiatowicz CS162 @UCB Fall 2006

Lec 10.14

Scheduling Assumptions

- CPU scheduling big area of research in early 70's
- Many implicit assumptions for CPU scheduling:
 - One program per user
 - One thread per program
 - Programs are independent
- Clearly, these are unrealistic but they simplify the problem so it can be solved
 - For instance: is "fair" about fairness among users or programs?
 - » If I run one compilation job and you run five, you get five times as much CPU on many operating systems
- The high-level goal: Dole out CPU time to optimize some desired parameters of system



10/2/06

Kubiatowicz CS162 @UCB Fall 2006

Lec 10.15

Assumption: CPU Bursts

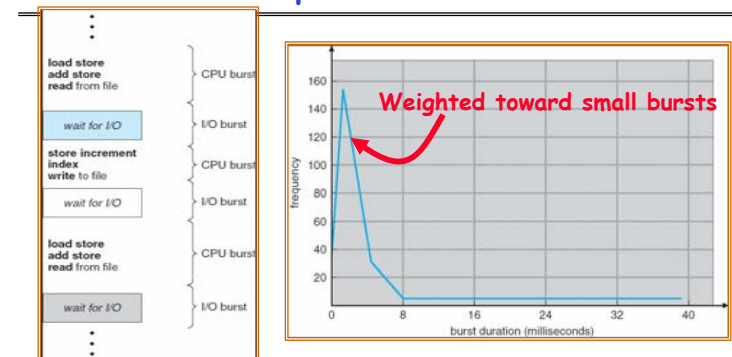

- Execution model: programs alternate between bursts of CPU and I/O
 - Program typically uses the CPU for some period of time, then does I/O, then uses CPU again
 - Each scheduling decision is about which job to give to the CPU for use by its next CPU burst
 - With timeslicing, thread may be forced to give up CPU before finishing current CPU burst

10/2/06

Kubiatowicz CS162 @UCB Fall 2006

Lec 10.16

Scheduling Policy Goals/Criteria

- **Minimize Response Time**
 - Minimize elapsed time to do an operation (or job)
 - Response time is what the user sees:
 - » Time to echo a keystroke in editor
 - » Time to compile a program
 - » Real-time Tasks: Must meet deadlines imposed by World
- **Maximize Throughput**
 - Maximize operations (or jobs) per second
 - Throughput related to response time, but not identical:
 - » Minimizing response time will lead to more context switching than if you only maximized throughput
 - Two parts to maximizing throughput
 - » Minimize overhead (for example, context-switching)
 - » Efficient use of resources (CPU, disk, memory, etc)
- **Fairness**
 - Share CPU among users in some equitable way
 - Fairness is not minimizing average response time:
 - » Better *average* response time by making system *less* fair

10/2/06

Kubiatowicz CS162 ©UCB Fall 2006

Lec 10.17

First-Come, First-Served (FCFS) Scheduling

- **First-Come, First-Served (FCFS)**
 - Also "First In, First Out" (FIFO) or "Run until done"
 - » In early systems, FCFS meant one program scheduled until done (including I/O)
 - » Now, means keep CPU until thread blocks
- **Example:**



Process	Burst Time
P_1	24
P_2	3
P_3	3

- Suppose processes arrive in the order: P_1, P_2, P_3
The Gantt Chart for the schedule is:

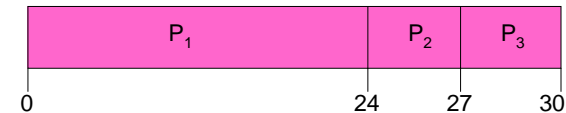

- Waiting time for $P_1 = 0$; $P_2 = 24$; $P_3 = 27$
- Average waiting time: $(0 + 24 + 27)/3 = 17$
- Average Completion time: $(24 + 27 + 30)/3 = 27$
- **Convoy effect:** short process behind long process

10/2/06

Kubiatowicz CS162 ©UCB Fall 2006

Lec 10.18

FCFS Scheduling (Cont.)

- **Example continued:**
 - Suppose that processes arrive in order: P_2, P_3, P_1
Now, the Gantt chart for the schedule is:

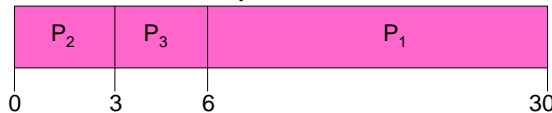

- Waiting time for $P_1 = 6$; $P_2 = 0$; $P_3 = 3$
- Average waiting time: $(6 + 0 + 3)/3 = 3$
- Average Completion time: $(3 + 6 + 30)/3 = 13$
- **In second case:**
 - average waiting time is much better (before it was 17)
 - Average completion time is better (before it was 27)
- **FIFO Pros and Cons:**
 - Simple (+)
 - Short jobs get stuck behind long ones (-)
 - » Safeway: Getting milk, always stuck behind cart full of small items. Upside: get to read about space aliens!

10/2/06

Kubiatowicz CS162 ©UCB Fall 2006

Lec 10.19

Round Robin (RR)

- **FCFS Scheme: Potentially bad for short jobs!**
 - Depends on submit order
 - If you are first in line at supermarket with milk, you don't care who is behind you, on the other hand...
- **Round Robin Scheme**
 - Each process gets a small unit of CPU time (*time quantum*), usually 10-100 milliseconds
 - After quantum expires, the process is preempted and added to the end of the ready queue.
 - n processes in ready queue and time quantum is $q \Rightarrow$
 - » Each process gets $1/n$ of the CPU time
 - » In chunks of at most q time units
 - » **No process waits more than $(n-1)q$ time units**
- **Performance**
 - q large \Rightarrow FCFS
 - q small \Rightarrow Interleaved (really small \Rightarrow hyperthreading?)
 - q must be large with respect to context switch, otherwise overhead is too high (all overhead)



10/2/06

Kubiatowicz CS162 ©UCB Fall 2006

Lec 10.20

Example of RR with Time Quantum = 20

• Example:

Process	Burst Time
P_1	53
P_2	8
P_3	68
P_4	24

- The Gantt chart is:

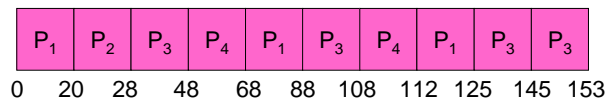

- Waiting time for $P_1=(68-20)+(112-88)=72$
 $P_2=(20-0)=20$
 $P_3=(28-0)+(88-48)+(125-108)=85$
 $P_4=(48-0)+(108-68)=88$
- Average waiting time = $(72+20+85+88)/4=66\frac{1}{4}$
- Average completion time = $(125+28+153+112)/4 = 104\frac{1}{2}$

• Thus, Round-Robin Pros and Cons:

- Better for short jobs, Fair (+)
- Context-switching time adds up for long jobs (-)

10/2/06

Kubiatowicz CS162 ©UCB Fall 2006

Lec 10.21

Round-Robin Discussion

• How do you choose time slice?

- What if too big?
 - » Response time suffers
- What if infinite (∞)?
 - » Get back FIFO
- What if time slice too small?
 - » Throughput suffers!

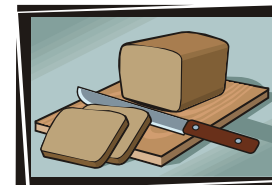

• Actual choices of timeslice:

- Initially, UNIX timeslice one second:
 - » Worked ok when UNIX was used by one or two people.
 - » What if three compilations going on? 3 seconds to echo each keystroke!
- In practice, need to balance short-job performance and long-job throughput:
 - » Typical time slice today is between **10ms - 100ms**
 - » Typical context-switching overhead is **0.1ms - 1ms**
 - » Roughly **1%** overhead due to context-switching

10/2/06

Kubiatowicz CS162 ©UCB Fall 2006

Lec 10.22

Comparisons between FCFS and Round Robin

- Assuming zero-cost context-switching time, is RR always better than FCFS?
- Simple example: 10 jobs, each take 100s of CPU time
 RR scheduler quantum of 1s
 All jobs start at the same time

• Completion Times:

Job #	FIFO	RR
1	100	991
2	200	992
...
9	900	999
10	1000	1000

- Both RR and FCFS finish at the same time
- Average response time is much worse under RR!
 - » Bad when all jobs same length
- Also: Cache state must be shared between all jobs with RR but can be devoted to each job with FIFO
 - Total time for RR longer even for zero-cost switch!

10/2/06

Kubiatowicz CS162 ©UCB Fall 2006

Lec 10.23

Earlier Example with Different Time Quantum

Best FCFS:

P_2 [8]	P_4 [24]	P_1 [53]	P_3 [68]	
0	8	32	85	153

	Quantum	P_1	P_2	P_3	P_4	Average
Wait Time	Best FCFS	32	0	85	8	$31\frac{1}{4}$
	Q = 1	84	22	85	57	62
	Q = 5	82	20	85	58	$61\frac{1}{4}$
	Q = 8	80	8	85	56	$57\frac{1}{4}$
	Q = 10	82	10	85	68	$61\frac{1}{4}$
	Q = 20	72	20	85	88	$66\frac{1}{4}$
Completion Time	Worst FCFS	68	145	0	121	$83\frac{1}{2}$
	Best FCFS	85	8	153	32	$69\frac{1}{2}$
	Q = 1	137	30	153	81	$100\frac{1}{2}$
	Q = 5	135	28	153	82	$99\frac{1}{2}$
	Q = 8	133	16	153	80	$95\frac{1}{2}$
	Q = 10	135	18	153	92	$99\frac{1}{2}$
Q = 20	125	28	153	112	$104\frac{1}{2}$	
Worst FCFS	121	153	68	145	$121\frac{1}{2}$	

10/2/06

Kubiatowicz CS162 ©UCB Fall 2006

Lec 10.24

What if we Knew the Future?

- Could we always mirror best FCFS?
- Shortest Job First (SJF):
 - Run whatever job has the least amount of computation to do
 - Sometimes called "Shortest Time to Completion First" (STCF)
- Shortest Remaining Time First (SRTF):
 - Preemptive version of SJF: if job arrives and has a shorter time to completion than the remaining time on the current job, immediately preempt CPU
 - Sometimes called "Shortest Remaining Time to Completion First" (SRTCF)
- These can be applied either to a whole program or the current CPU burst of each program
 - Idea is to get short jobs out of the system
 - Big effect on short jobs, only small effect on long ones
 - Result is better average response time



10/2/06

Kubiatowicz CS162 ©UCB Fall 2006

Lec 10.25

Discussion

- SJF/SRTF are the best you can do at minimizing average response time
 - Provably optimal (SJF among non-preemptive, SRTF among preemptive)
 - Since SRTF is always at least as good as SJF, focus on SRTF
- Comparison of SRTF with FCFS and RR
 - What if all jobs the same length?
 - » SRTF becomes the same as FCFS (i.e. FCFS is best can do if all jobs the same length)
 - What if jobs have varying length?
 - » SRTF (and RR): short jobs not stuck behind long ones

10/2/06

Kubiatowicz CS162 ©UCB Fall 2006

Lec 10.26

Example to illustrate benefits of SRTF

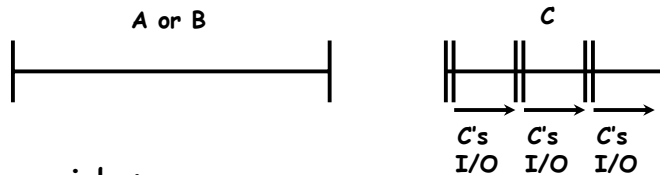

- Three jobs:
 - A, B: both CPU bound, run for week
 - C: I/O bound, loop 1ms CPU, 9ms disk I/O
 - If only one at a time, C uses 90% of the disk, A or B could use 100% of the CPU
- With FIFO:
 - Once A or B get in, keep CPU for two weeks
- What about RR or SRTF?
 - Easier to see with a timeline

10/2/06

Kubiatowicz CS162 ©UCB Fall 2006

Lec 10.27

SRTF Example continued:

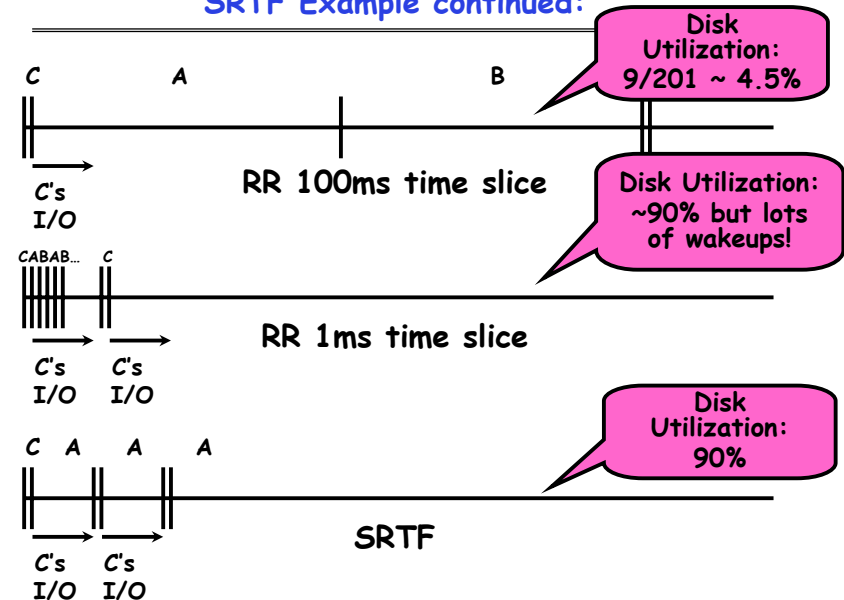

10/2/06

Kubiatowicz CS162 ©UCB Fall 2006

Lec 10.28

SRTF Further discussion

- **Starvation**
 - SRTF can lead to starvation if many small jobs!
 - Large jobs never get to run
- Somehow need to predict future
 - How can we do this?
 - Some systems ask the user
 - » When you submit a job, have to say how long it will take
 - » To stop cheating, system kills job if takes too long
 - But: Even non-malicious users have trouble predicting runtime of their jobs
- Bottom line, can't really know how long job will take
 - However, can use SRTF as a yardstick for measuring other policies
 - Optimal, so can't do any better
- SRTF Pros & Cons
 - Optimal (average response time) (+)
 - Hard to predict future (-)
 - Unfair (-)



10/2/06

Kubiatowicz CS162 ©UCB Fall 2006

10.29

Predicting the Length of the Next CPU Burst

- **Adaptive**: Changing policy based on past behavior
 - CPU scheduling, in virtual memory, in file systems, etc
 - Works because programs have predictable behavior
 - » If program was I/O bound in past, likely in future
 - » If computer behavior were random, wouldn't help
- Example: SRTF with estimated burst length
 - Use an estimator function on previous bursts: Let $t_{n-1}, t_{n-2}, t_{n-3}, \dots$ be previous CPU burst lengths. Estimate next burst $\tau_n = f(t_{n-1}, t_{n-2}, t_{n-3}, \dots)$
 - Function f could be one of many different time series estimation schemes (Kalman filters, etc)
 - For instance, **exponential averaging**

$$\tau_n = \alpha t_{n-1} + (1-\alpha)\tau_{n-1}$$
 with $(0 < \alpha \leq 1)$

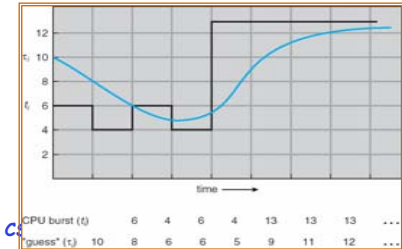

10/2/06

Kubiatowicz C

10.30

Multi-Level Feedback Scheduling

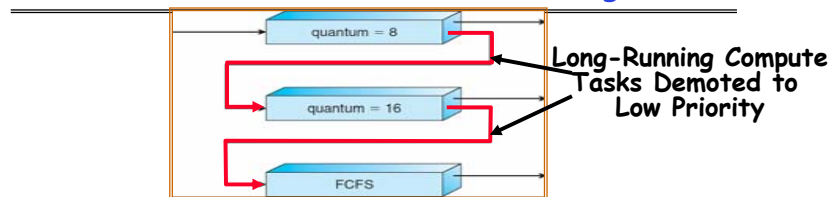

- Another method for exploiting past behavior
 - First used in CTSS
 - **Multiple queues, each with different priority**
 - » Higher priority queues often considered "foreground" tasks
 - **Each queue has its own scheduling algorithm**
 - » e.g. foreground - RR, background - FCFS
 - » Sometimes multiple RR priorities with quantum increasing exponentially (highest: 1ms, next: 2ms, next: 4ms, etc)
- Adjust each job's priority as follows (details vary)
 - Job starts in highest priority queue
 - If timeout expires, drop one level
 - If timeout doesn't expire, push up one level (or to top)

10/2/06

Kubiatowicz CS162 ©UCB Fall 2006

Lec 10.31

Scheduling Details

- Result approximates SRTF:
 - CPU bound jobs drop like a rock
 - Short-running I/O bound jobs stay near top
- Scheduling must be done between the queues
 - **Fixed priority scheduling**:
 - » serve all from highest priority, then next priority, etc.
 - **Time slice**:
 - » each queue gets a certain amount of CPU time
 - » e.g., 70% to highest, 20% next, 10% lowest
- **Countermeasure**: user action that can foil intent of the OS designer
 - For multilevel feedback, put in a bunch of meaningless I/O to keep job's priority high
 - Of course, if everyone did this, wouldn't work!
- Example of Othello program:
 - Playing against competitor, so key was to do computing at higher priority the competitors.
 - » Put in printf's, ran much faster!

10/2/06

Kubiatowicz CS162 ©UCB Fall 2006

Lec 10.32

What about Fairness?

- What about fairness?
 - Strict fixed-priority scheduling between queues is unfair (run highest, then next, etc):
 - » long running jobs may never get CPU
 - » In Multics, shut down machine, found 10-year-old job
 - Must give long-running jobs a fraction of the CPU even when there are shorter jobs to run
 - **Tradeoff: fairness gained by hurting avg response time!**
- How to implement fairness?
 - Could give each queue some fraction of the CPU
 - » What if one long-running job and 100 short-running ones?
 - » Like express lanes in a supermarket—sometimes express lanes get so long, get better service by going into one of the other lines
 - Could increase priority of jobs that don't get service
 - » What is done in UNIX
 - » This is ad hoc—what rate should you increase priorities?
 - » And, as system gets overloaded, no job gets CPU time, so everyone increases in priority \Rightarrow Interactive jobs suffer

10/2/06

Kubiatowicz CS162 ©UCB Fall 2006

Lec 10.33

Lottery Scheduling



- Yet another alternative: Lottery Scheduling
 - Give each job some number of lottery tickets
 - On each time slice, randomly pick a winning ticket
 - On average, CPU time is proportional to number of tickets given to each job
- How to assign tickets?
 - To approximate SRTF, short running jobs get more, long running jobs get fewer
 - To avoid starvation, every job gets at least one ticket (everyone makes progress)
- Advantage over strict priority scheduling: behaves gracefully as load changes
 - Adding or deleting a job affects all jobs proportionally, independent of how many tickets each job possesses

10/2/06

Kubiatowicz CS162 ©UCB Fall 2006

Lec 10.34

Lottery Scheduling Example

- Lottery Scheduling Example
 - Assume short jobs get 10 tickets, long jobs get 1 ticket

# short jobs/ # long jobs	% of CPU each short jobs gets	% of CPU each long jobs gets
1/1	91%	9%
0/2	N/A	50%
2/0	50%	N/A
10/1	9.9%	0.99%
1/10	50%	5%

- What if too many short jobs to give reasonable response time?
 - » In UNIX, if load average is 100, hard to make progress
 - » One approach: log some user out

10/2/06

Kubiatowicz CS162 ©UCB Fall 2006

Lec 10.35

How to Evaluate a Scheduling algorithm?

- Deterministic modeling
 - takes a predetermined workload and compute the performance of each algorithm for that workload
- Queuing models
 - Mathematical approach for handling stochastic workloads
- Implementation/Simulation:
 - Build system which allows actual algorithms to be run against actual data. Most flexible/general.

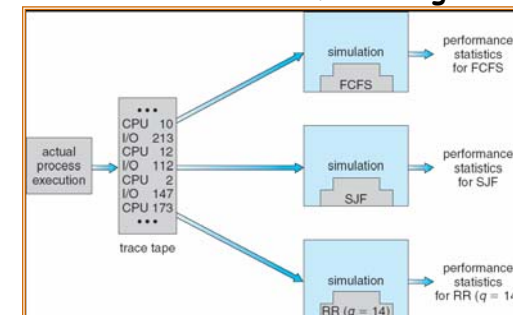

10/2/06

Kubiatowicz CS162 ©UCB Fall 2006

Lec 10.36

A Final Word on Scheduling

- When do the details of the scheduling policy and fairness really matter?
 - When there aren't enough resources to go around
- When should you simply buy a faster computer?
 - (Or network link, or expanded highway, or ...)
 - One approach: Buy it when it will pay for itself in improved response time
 - » Assuming you're paying for worse response time in reduced productivity, customer angst, etc...
 - » Might think that you should buy a faster X when X is utilized 100%, but usually, response time goes to infinity as utilization \Rightarrow 100%
- An interesting implication of this curve:
 - Most scheduling algorithms work fine in the "linear" portion of the load curve, fail otherwise
 - Argues for buying a faster X when hit "knee" of curve

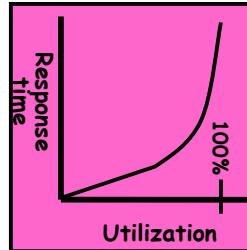

10/2/06

Kubiatowicz CS162 ©UCB Fall 2006

Lec 10.37

Summary (Deadlock)

- Four conditions required for deadlocks
 - **Mutual exclusion**
 - » Only one thread at a time can use a resource
 - **Hold and wait**
 - » Thread holding at least one resource is waiting to acquire additional resources held by other threads
 - **No preemption**
 - » Resources are released only voluntarily by the threads
 - **Circular wait**
 - » \exists set $\{T_1, \dots, T_n\}$ of threads with a cyclic waiting pattern
- Deadlock detection
 - Attempts to assess whether waiting graph can ever make progress
- Deadlock prevention
 - Assess, for each allocation, whether it has the potential to lead to deadlock
 - Banker's algorithm gives one way to assess this

10/2/06

Kubiatowicz CS162 ©UCB Fall 2006

Lec 10.38

Summary (Scheduling)

- **Scheduling**: selecting a waiting process from the ready queue and allocating the CPU to it
- **FCFS Scheduling**:
 - Run threads to completion in order of submission
 - Pros: Simple
 - Cons: Short jobs get stuck behind long ones
- **Round-Robin Scheduling**:
 - Give each thread a small amount of CPU time when it executes; cycle between all ready threads
 - Pros: Better for short jobs
 - Cons: Poor when jobs are same length

10/2/06

Kubiatowicz CS162 ©UCB Fall 2006

Lec 10.39

Summary (Scheduling 2)

- **Shortest Job First (SJF)/Shortest Remaining Time First (SRTF)**:
 - Run whatever job has the least amount of computation to do/least remaining amount of computation to do
 - Pros: Optimal (average response time)
 - Cons: Hard to predict future, Unfair
- **Multi-Level Feedback Scheduling**:
 - Multiple queues of different priorities
 - Automatic promotion/demotion of process priority in order to approximate SJF/SRTF
- **Lottery Scheduling**:
 - Give each thread a priority-dependent number of tokens (short tasks \Rightarrow more tokens)
 - Reserve a minimum number of tokens for every thread to ensure forward progress/fairness

10/2/06

Kubiatowicz CS162 ©UCB Fall 2006

Lec 10.40