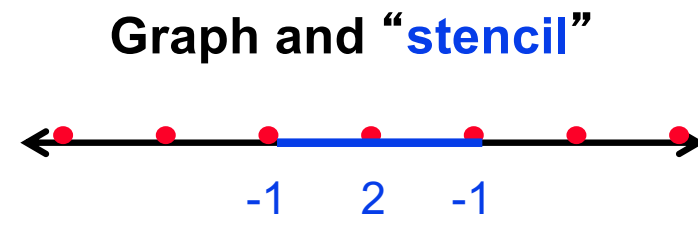

Ma221: Multigrid

James Demmel

people.eecs.berkeley.edu/~demmel

Poisson's equation in 1D: $\partial^2 u / \partial x^2 = f(x)$

$$T = \begin{pmatrix} 2 & -1 & & & & \\ -1 & 2 & -1 & & & \\ & -1 & 2 & -1 & & \\ & & -1 & 2 & -1 & \\ & & & -1 & 2 & \end{pmatrix}$$



Algorithms for 2D (3D) Poisson Equation ($N = n^2$ (n^3) vars)

Algorithm	Serial	PRAM	Memory	#Procs
◦ Dense Chol.	N^3	N	N^2	N^2
◦ Band Chol.	N^2 ($N^{7/3}$)	N	$N^{3/2}$ ($N^{5/3}$)	N ($N^{4/3}$)
◦ Jacobi	N^2 ($N^{5/3}$)	N ($N^{2/3}$)	N	N
◦ Explicit Inv.	N^2	$\log N$	N^2	N^2
◦ Conj.Gradients	$N^{3/2}$ ($N^{4/3}$)	$N^{1/2(1/3)} * \log N$	N	N
◦ Red/Black SOR	$N^{3/2}$ ($N^{4/3}$)	$N^{1/2}$ ($N^{1/3}$)	N	N
◦ Sparse Chol.	$N^{3/2}$ (N^2)	$N^{1/2}$ ($N^{2/3}$)	$N * \log N$ ($N^{4/3}$)	N ($N^{4/3}$)
◦ FFT	$N * \log N$	$\log N$	N	N
◦ Multigrid	N	$\log^2 N$	N	N
◦ Lower bound	N	$\log N$	N	

PRAM is an idealized parallel model with zero cost communication

Multigrid Motivation

Right Hand Side

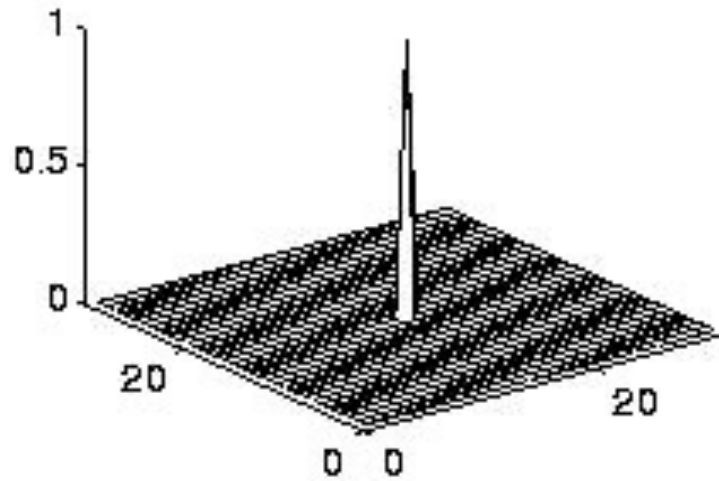

True Solution

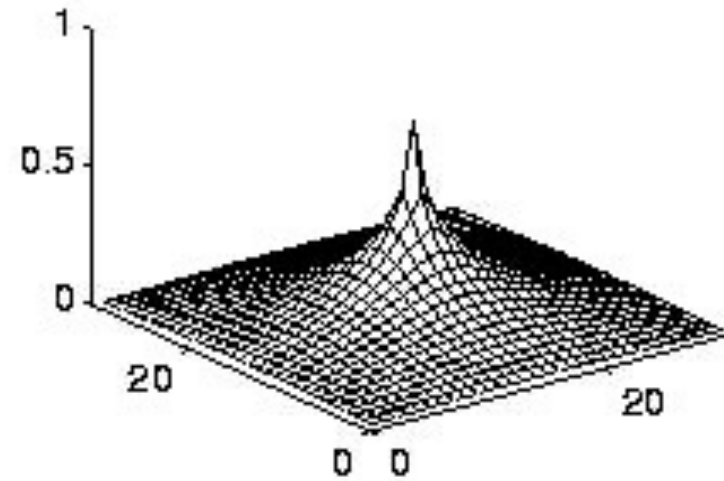

5 steps of Jacobi

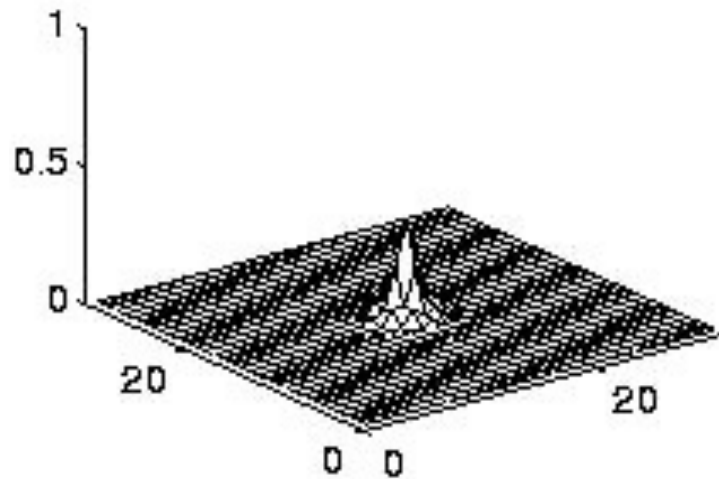

Best 5 step solution

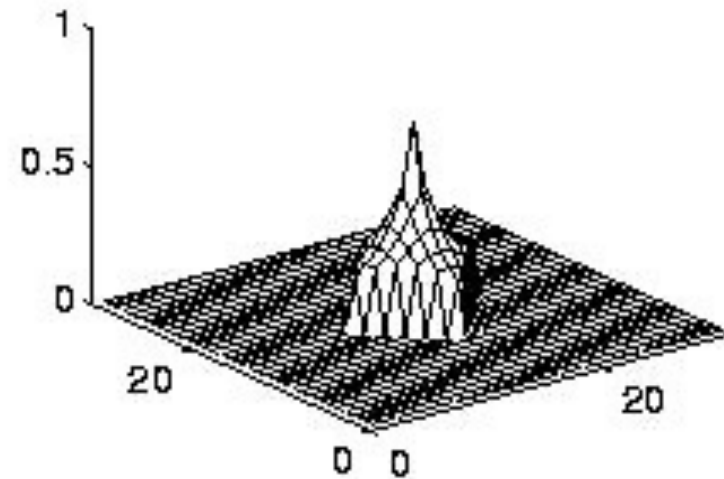

Multigrid Motivation

- **Recall that Jacobi, SOR, CG, or any other sparse-matrix-vector-multiply-based algorithm can only move information one grid cell at a time**
 - Take at least n steps to move information across $n \times n$ grid
- **Can show that decreasing error by fixed factor $c < 1$ takes $\Omega(\log n)$ steps**
 - Convergence to fixed error < 1 takes $\Omega(\log n)$ steps
- **Therefore, converging in $O(1)$ steps requires moving information across grid faster than to one neighboring grid cell per step**
 - One step can't just do sparse-matrix-vector-multiply

Big Idea used in multigrid and elsewhere

- **If you are far away, problem looks simpler**
 - For gravity: approximate earth, distant galaxies, ... by point masses
- **Can solve such a coarse approximation to get an approximate solution, iterating if necessary**
 - Solve coarse approximation problem by using an even coarser approximation of it, and so on recursively
- **Ex: Multigrid for solving PDE in $O(n)$ time**
 - Use coarser mesh to get approximate solution of Poisson's Eq.
- **Ex: Fast Multipole Method, Barnes-Hut for computing gravitational forces on n particles in $O(n \log n)$ time:**
 - Approximate particles in box by total mass, center of gravity
 - Good enough for distant particles; for close ones, divide box recursively
- **Ex: Graph Partitioning (used to parallelize SpMV)**
 - Replace graph to be partitioned by a coarser graph (CS267 for details)

Fine and Coarse Approximations

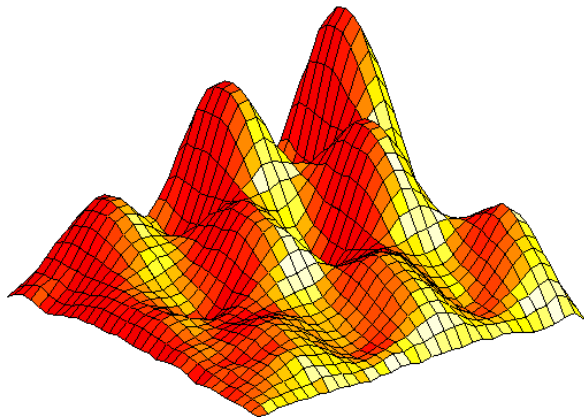

Fine

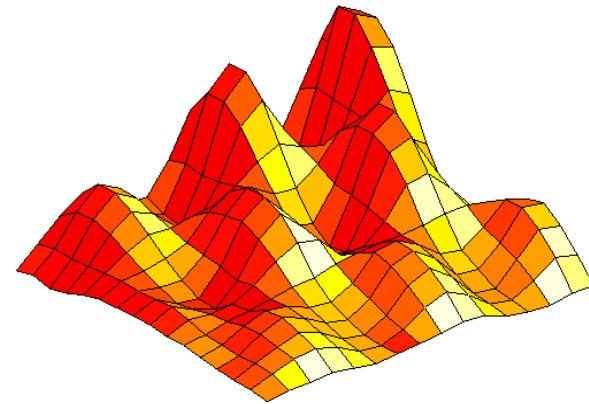

Coarse

Multigrid Overview

◦ Basic Algorithm:

- Replace problem on fine grid by an approximation on a coarser grid
- Solve the coarse grid problem approximately, and use the solution as a starting guess for the fine-grid problem, which is then iteratively updated
- Solve the coarse grid problem **recursively**, i.e. by using a still coarser grid approximation, etc.

◦ Success depends on coarse grid solution being a good approximation to the fine grid

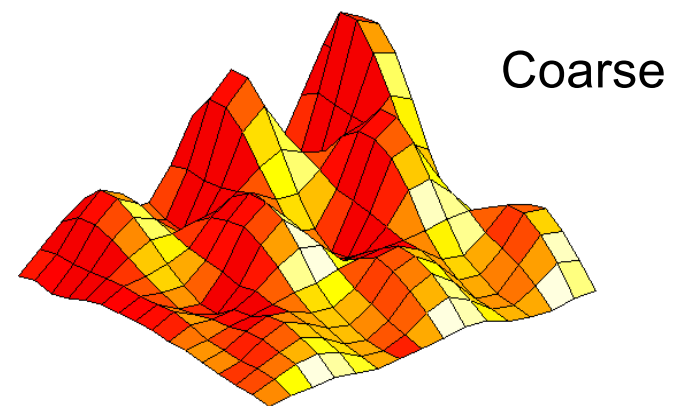
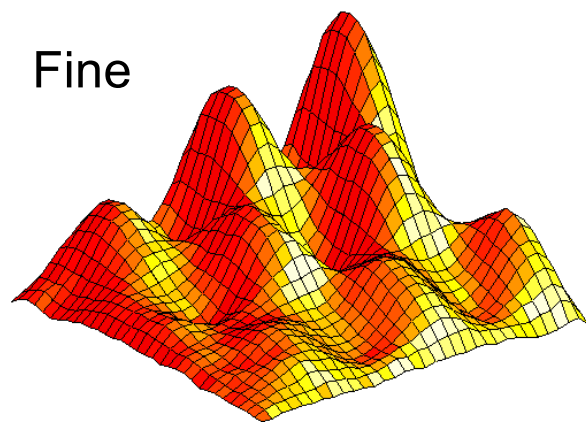

Multigrid uses Divide-and-Conquer in 2 Ways

- **First way:**
 - Solve problem on a given grid by calling Multigrid on a coarse approximation to get a good guess to refine
- **Second way:**
 - Think of error as a sum of sine curves of different frequencies
 - Same idea as FFT solution, but not explicit in algorithm
 - Each call to Multigrid responsible for suppressing coefficients of sine curves of the upper half of the frequencies in the error (pictures later)

Multigrid Sketch in 1D

- Consider a 2^m+1 grid in 1D for simplicity
- Let $P^{(i)}$ be the problem of solving the discrete Poisson equation on a 2^i+1 grid in 1D. Write linear system as $T(i) * x(i) = b(i)$
- $P^{(m)}, P^{(m-1)}, \dots, P^{(1)}$ is sequence of problems from finest to coarsest

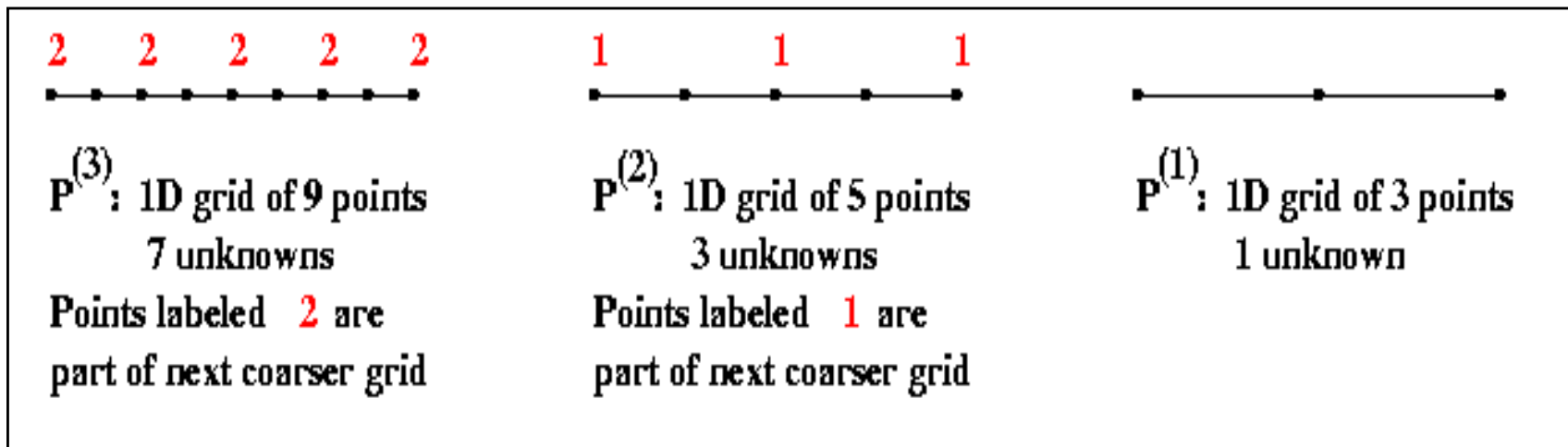

Multigrid Sketch (1D and 2D)

- Consider a 2^m+1 grid in 1D (2^m+1 by 2^m+1 grid in 2D) for simplicity
- Let $P^{(i)}$ be the problem of solving the discrete Poisson equation on a 2^i+1 grid in 1D (2^i+1 by 2^i+1 grid in 2D)
 - Write linear system as $T(i) * x(i) = b(i)$
- $P^{(m)}, P^{(m-1)}, \dots, P^{(1)}$ is sequence of problems from finest to coarsest

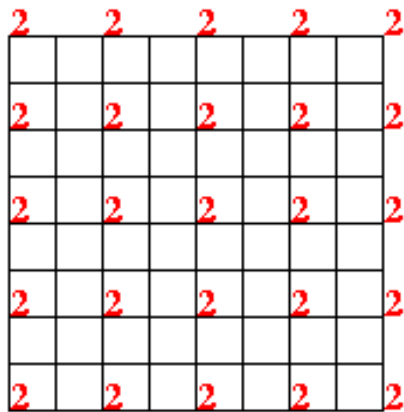

$P^{(3)}$: 9 by 9 grid of points
 7 by 7 grid of unknowns
 Points labeled **2** are
 part of next coarser grid

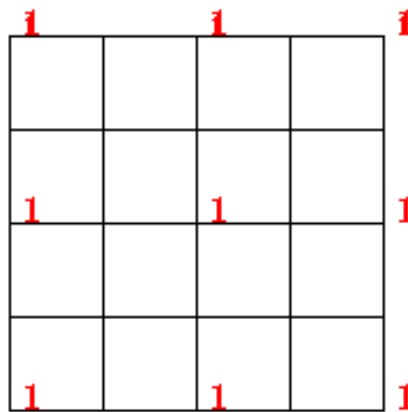

$P^{(2)}$: 5 by 5 grid of points
 3 by 3 grid of unknowns
 Points labeled **1** are
 part of next coarser grid

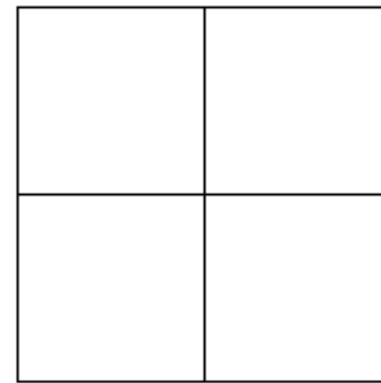

$P^{(1)}$: 3 by 3 grid of points
 1 by 1 grid of unknowns

Multigrid Operators

- For problem $P^{(i)}$:
 - $b^{(i)}$ is the RHS and
 - $x^{(i)}$ is the current estimated solution } both live on grids of size 2^{i-1}
- All the following operators just average values on neighboring grid points (so information moves fast on coarse grids)
- The **restriction operator $R^{(i)}$** maps $P^{(i)}$ to $P^{(i-1)}$
 - Restricts problem on fine grid $P^{(i)}$ to coarse grid $P^{(i-1)}$
 - Uses sampling or averaging
 - $b^{(i-1)} = R^{(i)}(b^{(i)})$
- The **interpolation operator $I_n^{(i-1)}$** maps approx. solution $x^{(i-1)}$ to $x^{(i)}$
 - Interpolates solution on coarse grid $P^{(i-1)}$ to fine grid $P^{(i)}$
 - $x^{(i)} = I_n^{(i-1)}(x^{(i-1)})$
- The **solution operator $S^{(i)}$** takes $P^{(i)}$ and improves solution $x^{(i)}$
 - Uses “weighted” Jacobi or SOR on single level of grid
 - $x_{\text{improved}}^{(i)} = S^{(i)}(b^{(i)}, x^{(i)})$
- Overall algorithm, then details of operators

Multigrid V-Cycle Algorithm (Matlab code on webpage)

Function MGV (b(i), x(i))

... Solve $T(i)*x(i) = b(i)$ given b(i) and an initial guess for x(i)

... return an improved x(i)

if (i = 1)

compute exact solution x(1) of $P^{(1)}$

only 1 unknown

return x(1)

else

$x(i) = S(i) (b(i), x(i))$

improve solution by

damping high frequency error

$r(i) = T(i)*x(i) - b(i)$

compute residual

$d(i) = \ln(i-1) (MGV(R(i) (r(i)), 0))$

solve $T(i)*d(i) = r(i)$ recursively

$x(i) = x(i) - d(i)$

correct fine grid solution

$x(i) = S(i) (b(i), x(i))$

improve solution again

return x(i)

Why is this called a V-Cycle?

- Just a picture of the call graph
- In time a V-cycle looks like the following

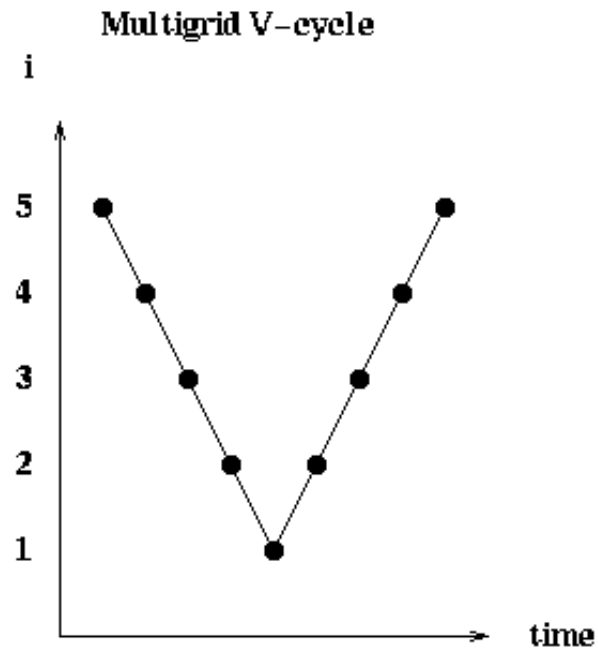

Cost (#flops) of a V-Cycle for 2D Poisson

- **Constant work per mesh point (average with neighbors)**
- **Work at each level in a V-cycle is $O(\text{the number of unknowns})$**
- **Cost of Level i is $O((2^i-1)^2) = O(4^i)$**
- **If finest grid level is m , total time is:**

$$\sum_{i=1}^m O(4^i) = O(4^m) = O(\# \text{ unknowns})$$

Full Multigrid (FMG)

◦ **Intuition:**

- improve solution by doing multiple V-cycles
- avoid expensive fine-grid (high frequency) cycles
- analysis of why this works is beyond the scope of this class

Function FMG (b(m), x(m))

... return improved x(m) given initial guess

compute the exact solution x(1) of P(1)

for i=2 to m

x(i) = MG (b(i), In (i-1) (x(i-1)))

◦ **In other words:**

- Solve the problem with 1 unknown
- Given a solution to the coarser problem, $P^{(i-1)}$, map it to starting guess for $P^{(i)}$
- Solve the finer problem using the Multigrid V-cycle

Full Multigrid Cost Analysis

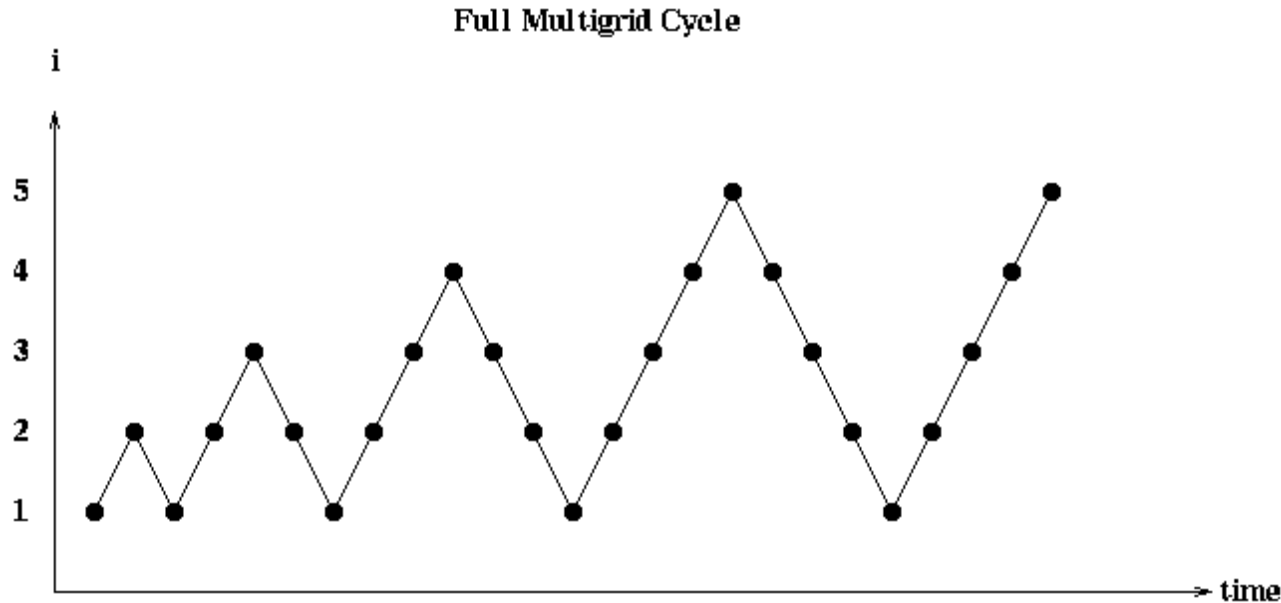

- **One V-cycle for each call to FMG**
 - people also use “W cycles” and other compositions
- **#Flops:** $\sum_{i=1}^m O(4^i) = O(4^m) = O(\# \text{ unknowns})$

Complexity of Solving Poisson's Equation

- **Theorem: error after one FMG call $\leq c \cdot$ error before, where $c < 1/2$, independent of # unknowns**
- **Corollary: We can make the error $<$ any fixed tolerance in a fixed number of steps, independent of size of finest grid**
- **This is the most important convergence property of MG, distinguishing it from all other methods, which converge more slowly for large grids**
- **Total complexity just proportional to cost of one FMG call**

The Solution Operator $S(i)$ – Details

- The solution operator, $S(i)$, is a weighted Jacobi
- Consider the 1D problem

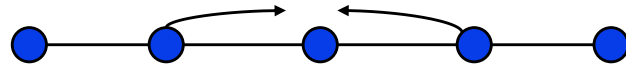

- At level i , pure Jacobi replaces:

$$x(j) := 1/2 (x(j-1) + x(j+1) + b(j))$$

in notation from lecture: $R_J = I - T/2$

- Weighted Jacobi uses:

$$x(j) := 1/3 (x(j-1) + x(j) + x(j+1) + b(j))$$

$$R_{wJ} = I - T/3$$

- In 2D, similar average of nearest neighbors
 - Chosen so that “high frequency” eigenvector components of error get decreased by as much as possible (1/3)

Eigenvalues of Solution Operator $S(i)$ ($R_{wJ} = I - T/3$)

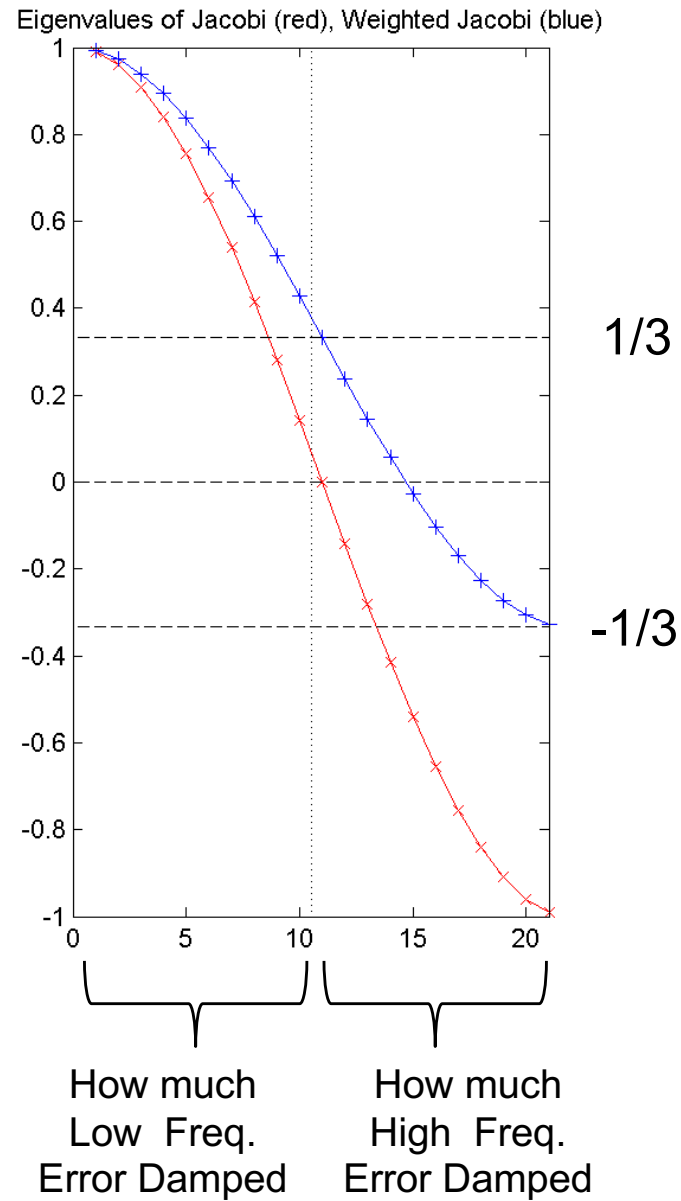
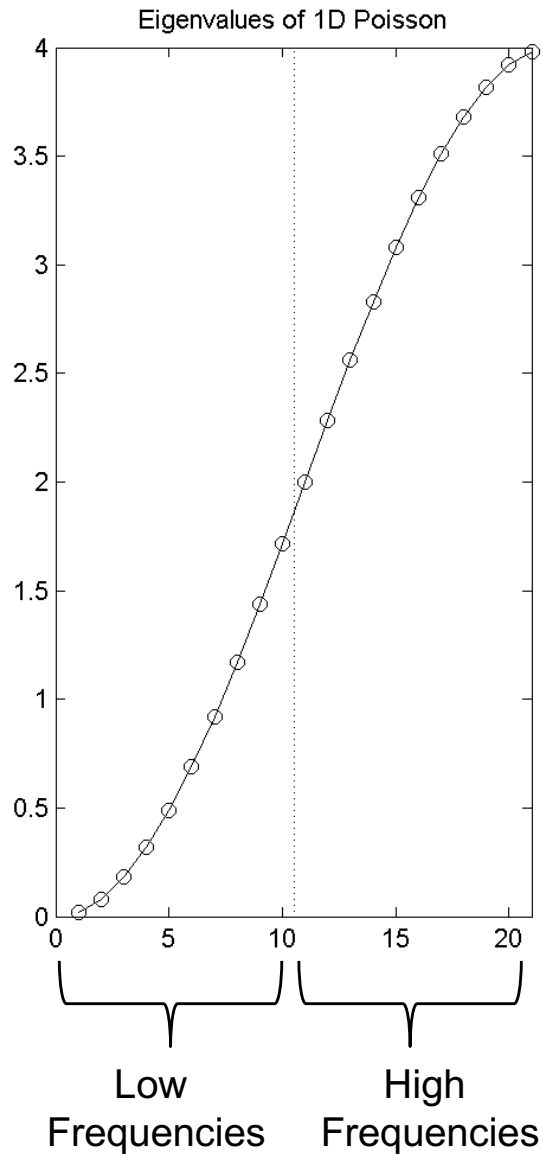

Weighted Jacobi chosen to damp high frequency error

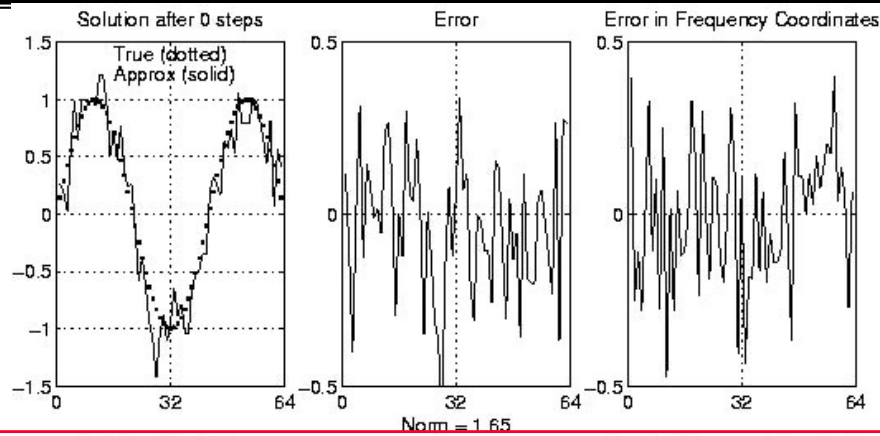

Initial error
“Rough”
Lots of high frequency components
Norm = 1.65

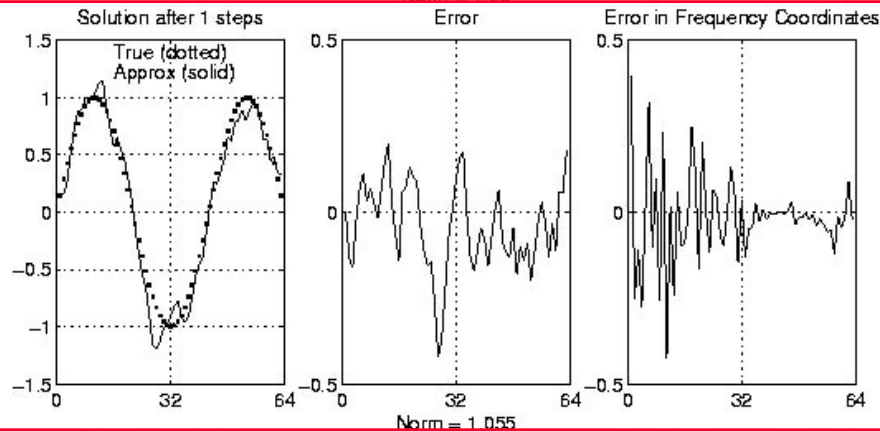

Error after 1 weighted Jacobi step
“Smoother”
Less high frequency component
Norm = 1.06

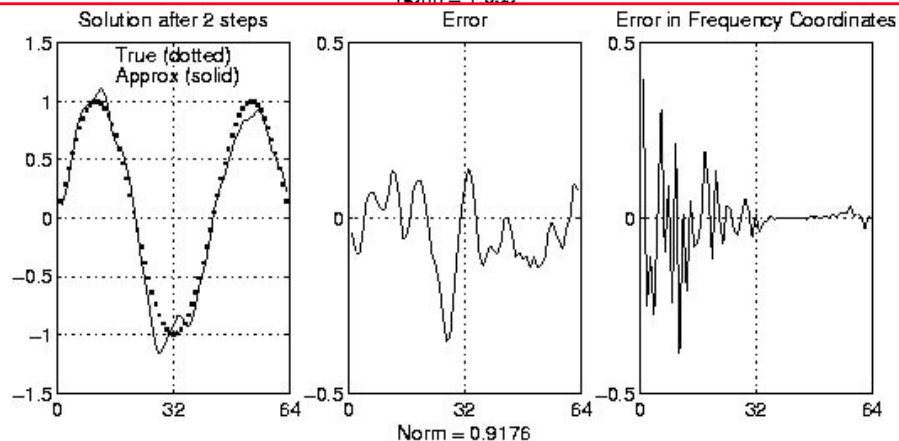

Error after 2 weighted Jacobi steps
“Smooth”
Little high frequency component
Norm = .92,
won't decrease much more

Multigrid as Divide and Conquer Algorithm

- Each level in a V-Cycle reduces the error in one part of the frequency domain

Schematic Description of Multigrid

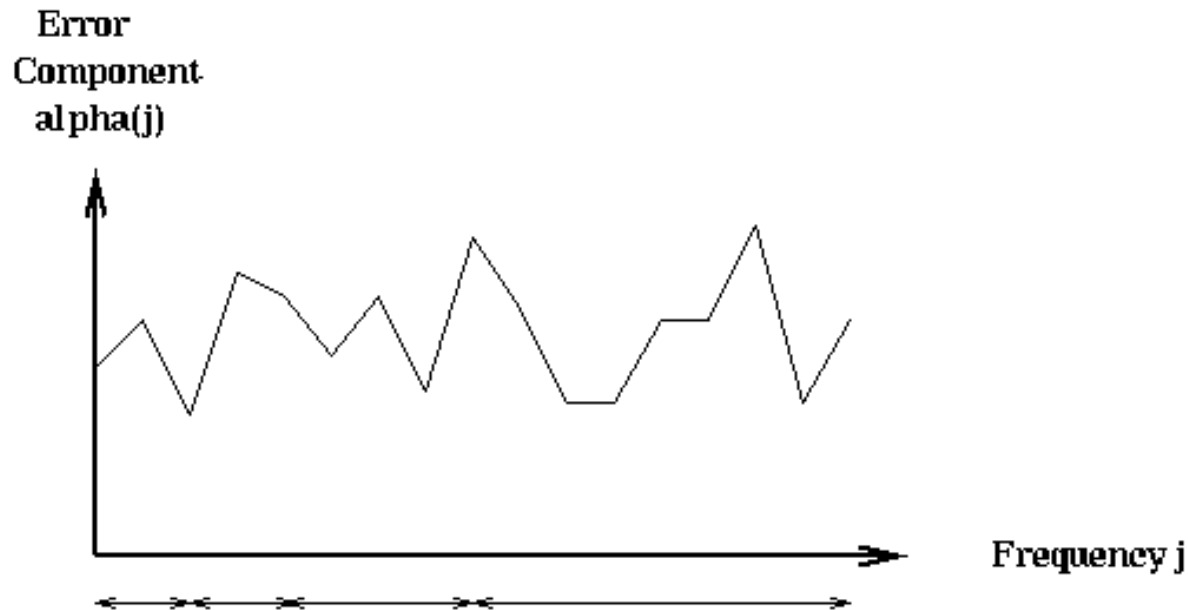

P(1) Upper half of freqs. on P(2) Upper half of freqs. on P(3) Upper half of frequencies on P(4)

Error on fine and coarse grids

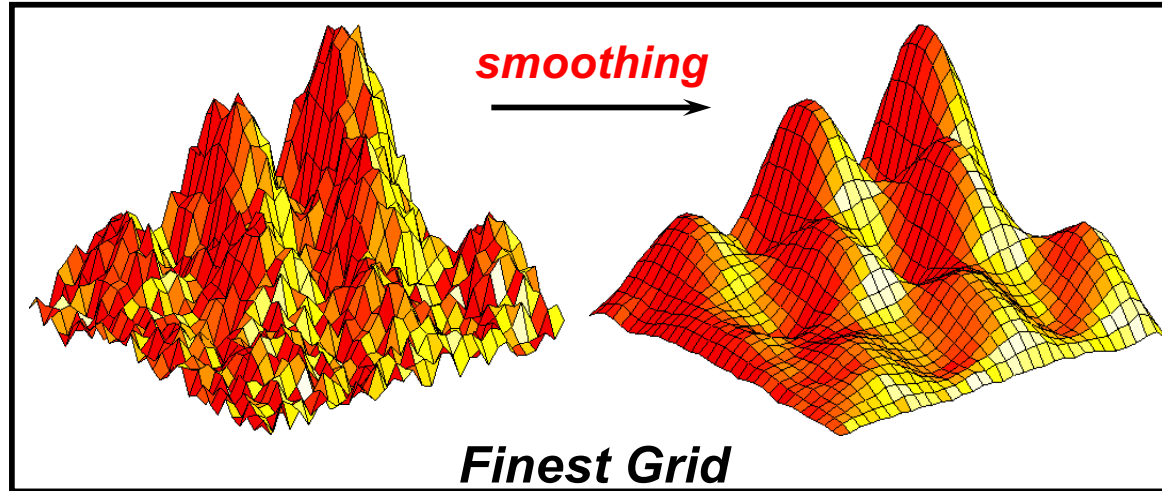

↓ *Restriction (R)*

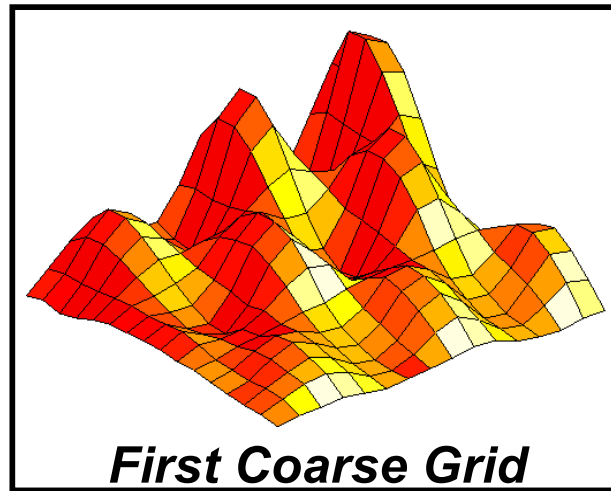

The Restriction Operator $R(i)$ - Details

- The restriction operator, $R(i)$, takes
 - a problem $P^{(i)}$ with Right-Hand-Side (RHS) b_{fine} and
 - maps it to a coarser problem $P^{(i-1)}$ with RHS $b_{\text{coarse}} = R(i)(b_{\text{fine}})$
- In 1D, average values of neighbors
 - Simplest: Sampling: $b_{\text{coarse}}(k) = b_{\text{fine}}(k)$
 - Better: Averaging: $b_{\text{coarse}}(k) = 1/4 * b_{\text{fine}}(k-1) + 1/2 * b_{\text{fine}}(k) + 1/4 * b_{\text{fine}}(k+1)$

Simplest: Sampling

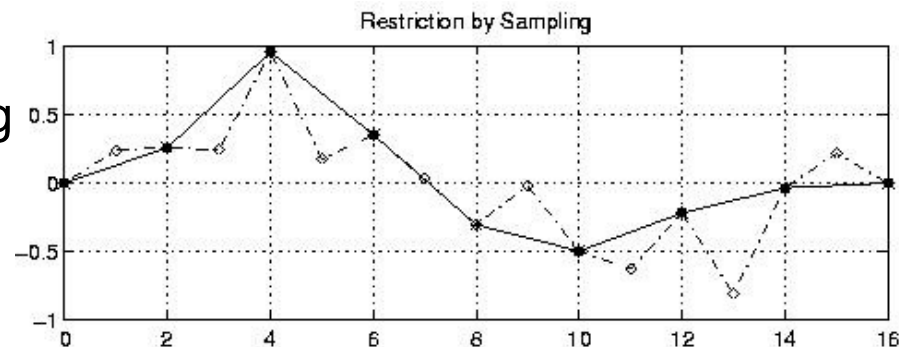

Better: Averaging

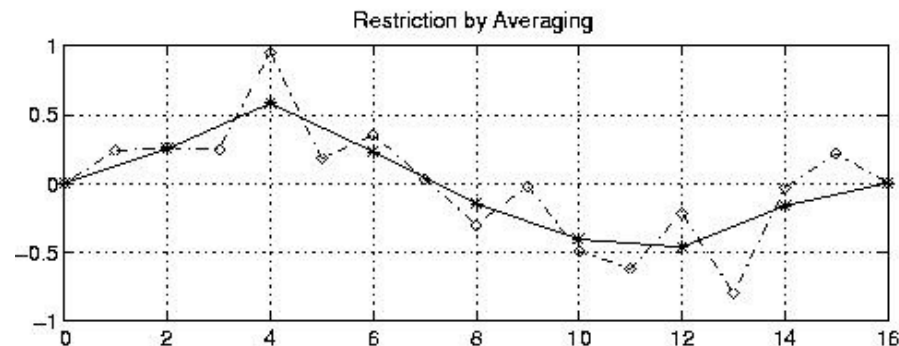

- In 2D, average with all 8 neighbors (N,S,E,W,NE,NW,SE,SW)

Interpolation Operator $\text{In}(i-1)$: details

- The interpolation operator $\text{In}(i-1)$, takes a function x_{coarse} on a coarse grid $P^{(i-1)}$, and produces a function x_{fine} on a fine grid $P^{(i)}$:
 - $x_{\text{fine}} = \text{In}(i-1)(x_{\text{coarse}})$
- In 1D, linearly interpolate nearest coarse neighbors
 - $x_{\text{fine}}(k) = x_{\text{coarse}}(k)$ if the fine grid point k is also a coarse one, else
 - $x_{\text{fine}}(k) = 1/2 * x_{\text{coarse}}(\text{left of } k) + 1/2 * x_{\text{coarse}}(\text{right of } k)$

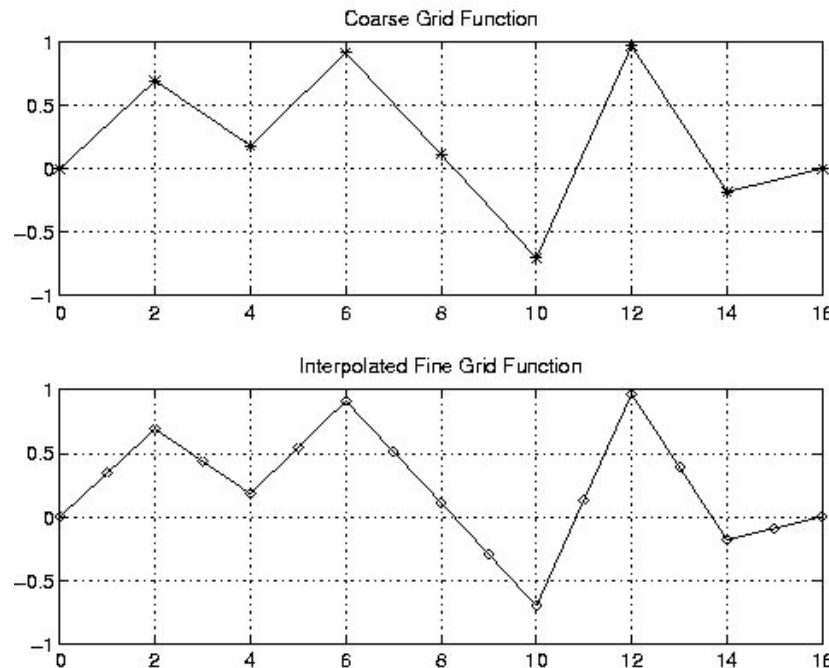

- In 2D, interpolation requires averaging with 4 nearest neighbors (NW,SW,NE,SE)

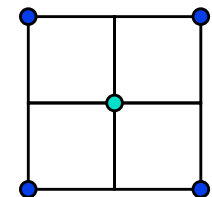

Convergence Picture of Multigrid in 1D

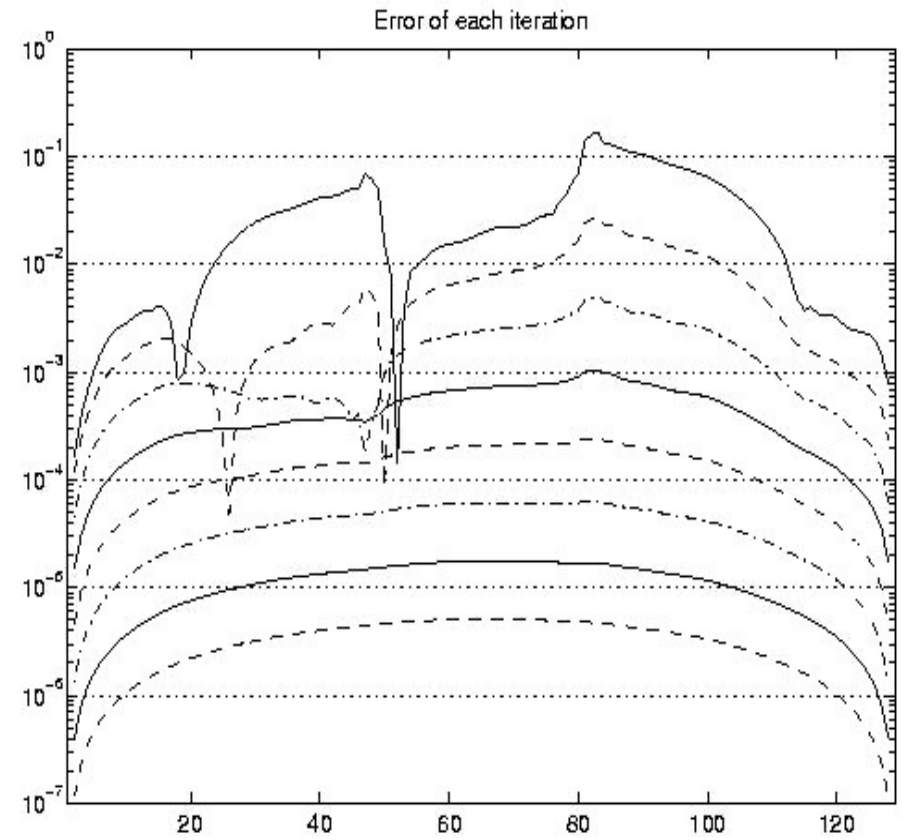
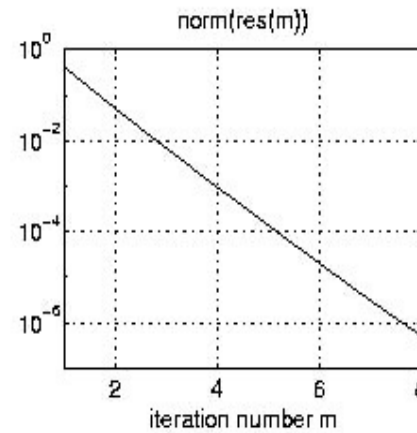
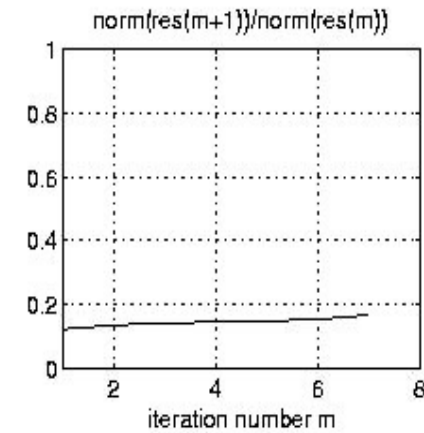
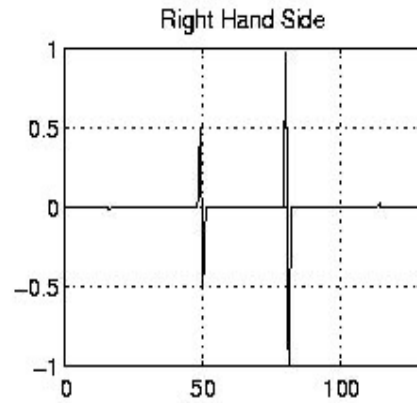
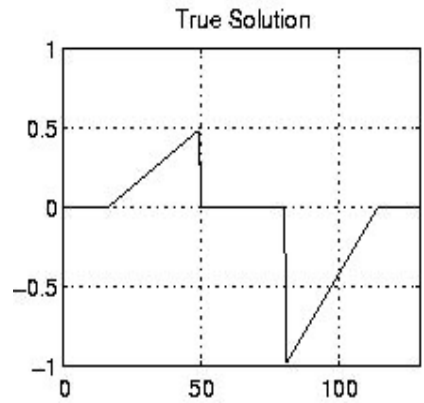

Convergence Picture of Multigrid in 2D

True Solution

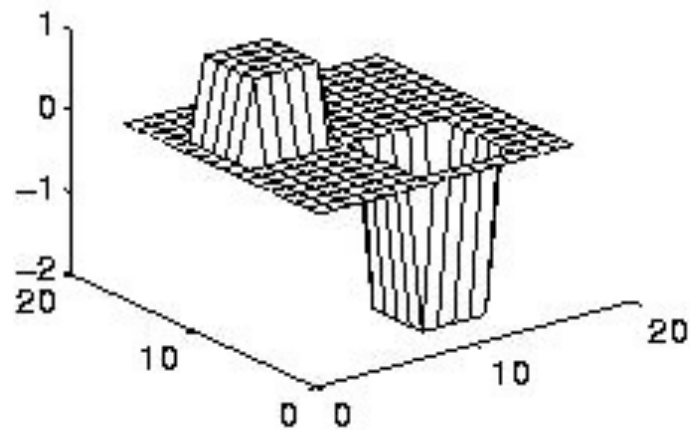

Right Hand Side

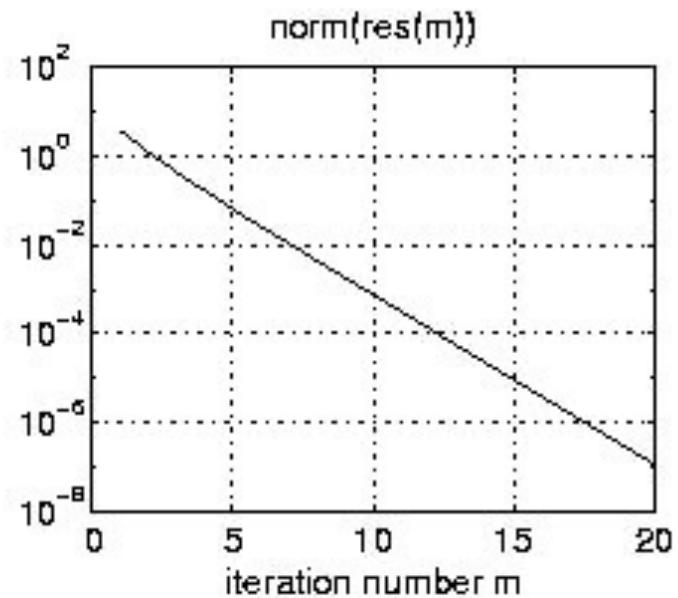
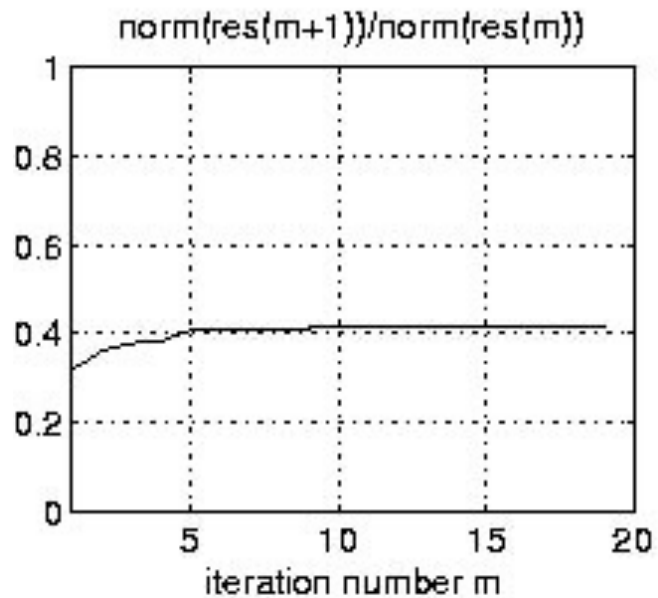
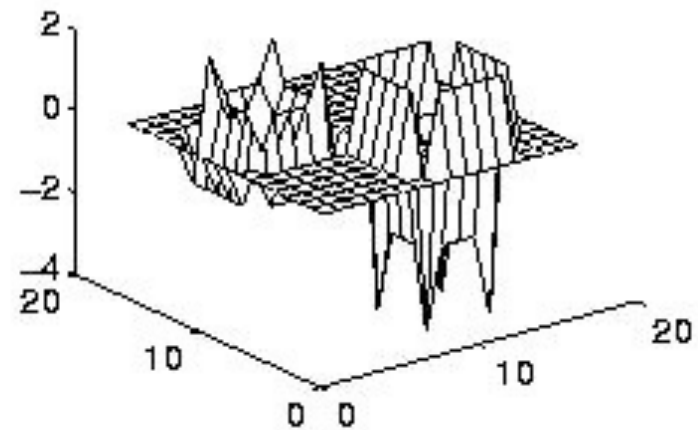

Multigrid V-Cycle Algorithm Analysis (1/2)

Function MGV (b(i), x(i))

... Solve $T(i) \cdot x(i) = b(i)$ given $b(i)$ and an initial guess for $x(i)$

... return an improved $x(i)$

if (i = 1)

compute exact solution $x(1)$ of $P^{(1)}$

only 1 unknown

return $x(1)$

else

$x(i) = S(i) (b(i), x(i))$

$x(i) = S \cdot x(i) + b(i)/3$

$r(i) = T(i) \cdot x(i) - b(i)$

$r(i) = T(i) \cdot x(i) - b(i)$

$d(i) = I_n(i-1) (MGV(R(i) (r(i)), 0))$

$d(i) = I_n \cdot (T(i-1)^{-1} \cdot (R \cdot r(i)))$

(Note: we assume recursive solve is exact, for ease of analysis)

$x(i) = x(i) - d(i)$

$x(i) = x(i) - d(i)$

$x(i) = S(i) (b(i), x(i))$

$x(i) = S \cdot x(i) + b(i)/3$

return $x(i)$

Multigrid V-Cycle Algorithm Analysis (2/2)

Goal: combine these equations to get formula for error $e(i) = x(i) - x$:

$$x(i) = S \cdot x(i) + b(i)/3$$

$$\text{subtract } x = S \cdot x + b(i)/3 \text{ to get } e(i) = S \cdot e(i)$$

$$r(i) = T(i) \cdot x(i) - b(i)$$

$$\text{subtract } 0 = T(i) \cdot x - b(i) \text{ to get } r(i) = T(i) \cdot e(i)$$

$$d(i) = I_n \cdot (T(i-1)^{-1} \cdot (R \cdot r(i)))$$

assume coarse problem solved exactly

$$x(i) = x(i) - d(i)$$

$$\text{subtract } x = x \text{ to get } e(i) = e(i) - d(i)$$

$$x(i) = S \cdot x(i) + b(i)/3$$

$$\text{subtract } x = S \cdot x + b(i)/3 \text{ to get } e(i) = S \cdot e(i)$$

Substitute each equation into later ones to get

$$e(i) = S \cdot (I - I_n \cdot (T(i-1)^{-1} \cdot (R \cdot T(i)))) \cdot S \cdot e(i) \equiv M \cdot e(i)$$

Theorem: For 1D Poisson problem, the eigenvalues of M are either 0 or 1/9, independent of dimension.

This means multigrid converges in a bounded number of steps, independent of dimension.

Generalizing Multigrid beyond Poisson, to unstructured meshes (1/2)

- **What does it mean to do Multigrid anyway?**
- **Need to be able to coarsen grid (hard problem)**
 - Can't just pick "every other grid point" anymore
 - How to make coarse graph approximate fine one
 - What if there are no grid points?
- **Need to define $R()$ and $I_n()$**
 - How do we convert from coarse to fine mesh and back?
 - How do we define coarse matrix (no longer formula, like Poisson)
- **Need to define $S()$**
 - How do we damp "high frequency" error?
- **Dealing with coarse meshes efficiently**
 - Should we switch to another solver on coarsest meshes?

Generalizing Multigrid beyond Poisson, to unstructured meshes (2/2)

- **Given original problem, how do we generate a sequence of coarse approximations?**
- **For finite element problems, could regenerate matrix starting on coarser mesh**
 - Need access to original physical problem and finite element modeling system, i.e. a lot more than just the original matrix, so it may be impossible
 - What does “coarse” mean, once very coarse?
- **Geometric Multigrid**
 - Assume we know (x,y,z) coordinates of underlying mesh, and matrix
 - Generate coarse mesh points, analogous to taking every other point in regular mesh
 - Retriangulate to get new mesh
 - Use finite element shape functions on coarse mesh to project fine matrix to coarse one
- **Algebraic Multigrid**
 - Don't even have (x,y,z) coordinates, just matrix

Geometric Multigrid

- **Need matrix, (x,y,z) coordinates of mesh points**
 - Not minimum information (just matrix), but a little more
 - Based on work of Guillard, Chan, Smith
- **Finite element intuition**
 - Goal is to compute function, represented by values at points
 - Think of approximation by piecewise linear function connecting points
 - Easy in 1D, need triangulated mesh in 2D, 3D uses tetrahedra
- **Geometric coarsening**
 - Pick a subset of coarse points “evenly spaced” among fine points
 - Use Maximal Independent Sets
 - Try to keep important points, like corners, edges of object
 - Retriangulate coarse points
 - Try to approximate answer by piecewise linear function on new triangles
 - Let columns of P (“prolongator”) be values at fine grid points given values at coarse ones
 - Generalizes Interpolation operator “ In ” from before
 - $A_{\text{coarse}} = P^T A_{\text{fine}} P$ – Galerkin method
 - For Poisson: $P = In$, $P^T = 2 * R$, $T_{\text{coarse}} = 2 * P^T * T_{\text{fine}} * P$

Example of Geometric Coarsening

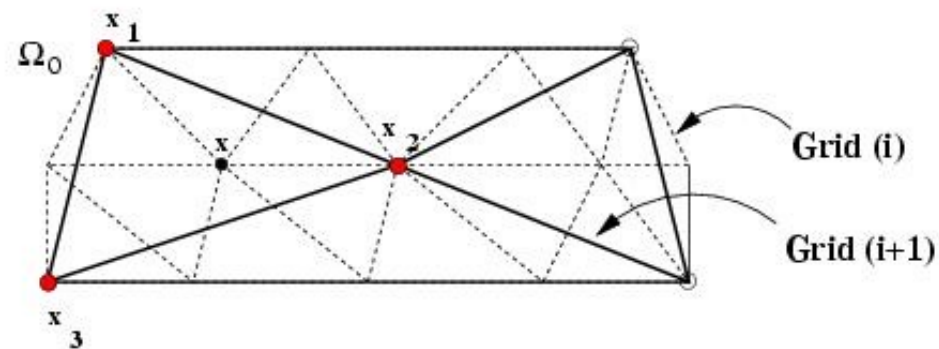

Simple Greedy Algorithm:

repeat
 pick unmarked vertex
 mark it and its neighbors
until no unmarked vertices

Examples of meshes from geometric coarsening

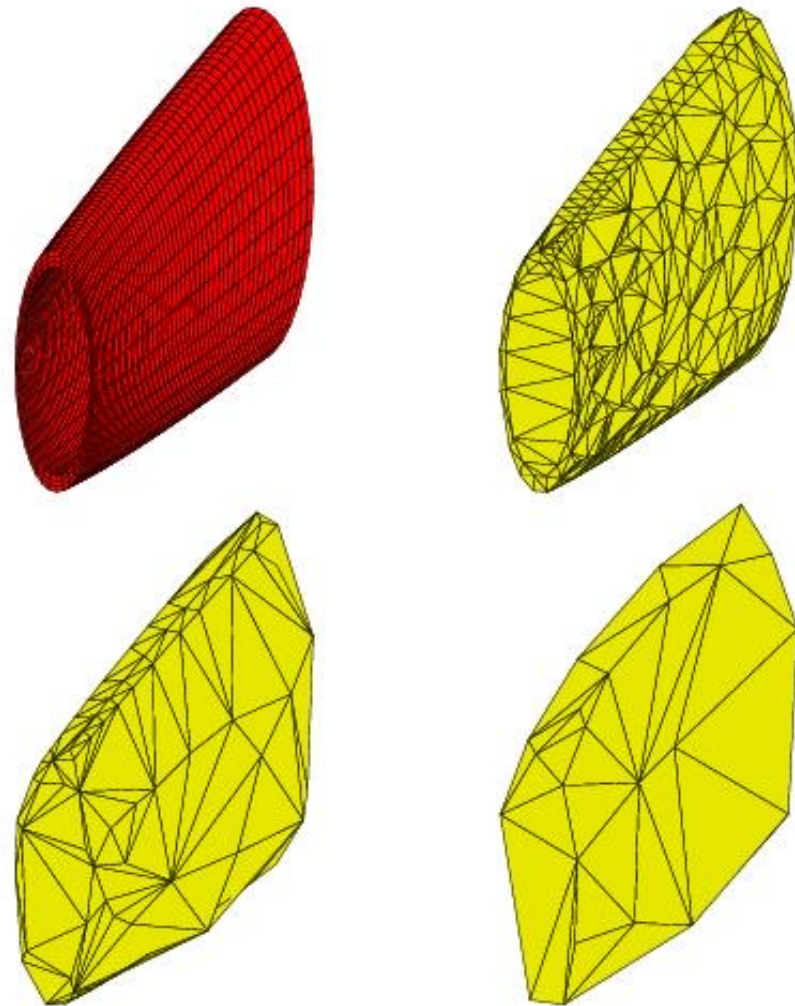
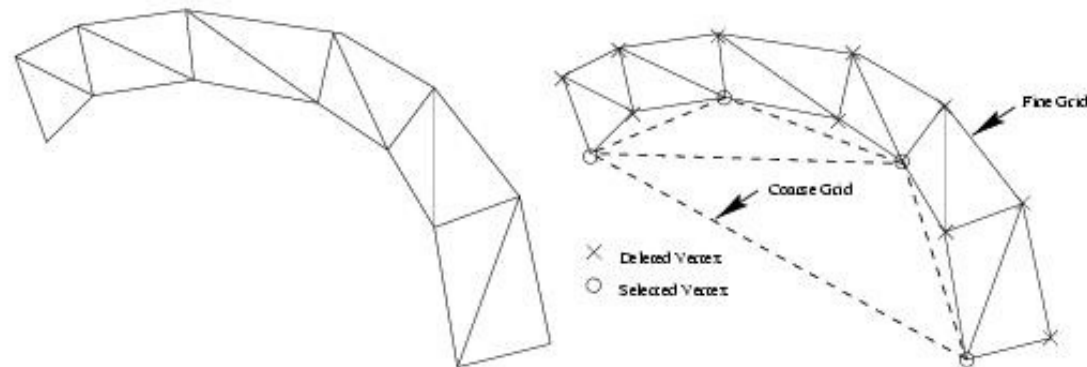

Figure 6: Sample input grid and coarse grids

What can go wrong

- Care needed so coarse grid preserves geometric features of fine grid
 - Label fine grid points as corner, edge, face, interior
 - Delete edges between same-labeled points in different features
 - Ex: delete edges between points on different faces
 - Keeps feature represented on coarse meshes

Pathological example:



How to coarsen carefully

Example - classify vertices - modify graph

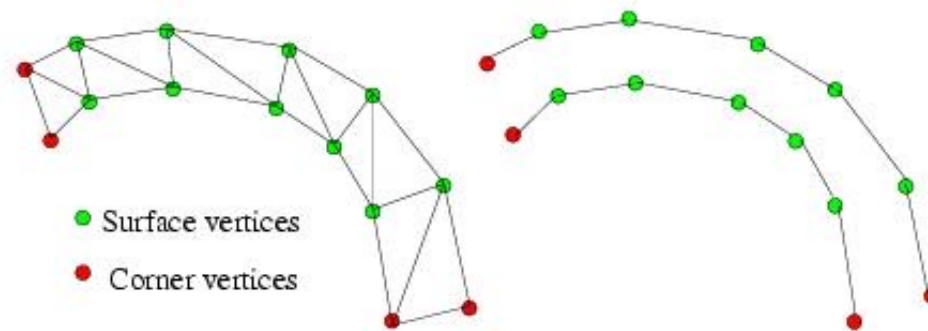

Figure 1: Modify graph

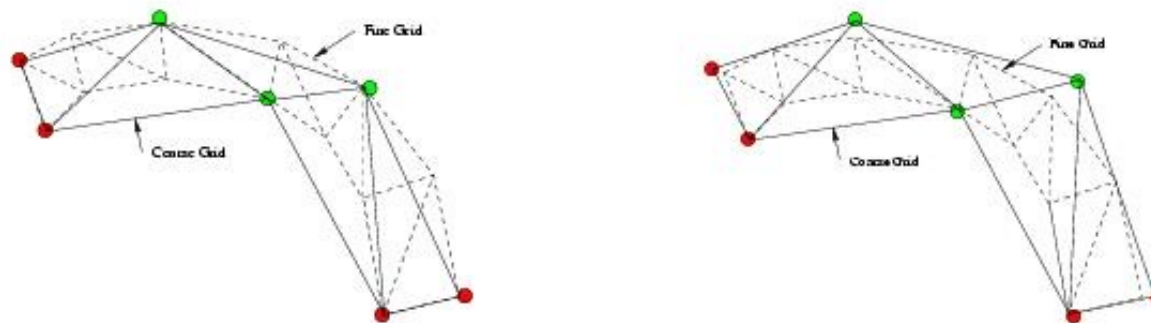

Figure 2: New mesh - fixed mesh

Algebraic Multigrid

- **No information beyond matrix needed**
- **Galerkin still used to get $A_{\text{coarse}} = P^T A_{\text{fine}} P$**
- **Prolongator P defined purely algebraically**
 - **Cluster fine grid points into nearby groups**
 - **Can use Maximal Independent Sets or Graph Partitioning**
 - **Use magnitude of entries of A_{fine} to cluster**
 - **Associate one coarse grid node to each group**
 - **To interpolate coarse grid values to associated fine grid point, can use properties of PDE, eg elasticity:**
 - **Rigid body modes of coarse grid point**
 - **Let coarse grid point have 6 dof (3 translation, 3 rotation)**
 - **Can be gotten from QR factorization of submatrix of A_{fine}**
 - **Can also apply smoother to resulting columns of P**
 - **“Smoothed Aggregation”**
- **Based on work of Vanek, Mandel, Brezina, Farhat, Roux, Bulgakov, Kuhn ...**

Parallel Smoothers for Unstructured Multigrid

- **Weighted Jacobi**
 - Easy to implement, hard to choose weight
- **Gauss-Seidel**
 - Works well, harder to parallelize because of triangular solve
- **Polynomial Smoothers**
 - Chebyshev polynomial $p(\mathbf{A}_{\text{fine}})$
 - Easy to implement (just SpMV with \mathbf{A}_{fine})
 - Chebyshev chooses $p(y)$ such that
 - $|1 - p(y) y| = \min$ over interval $[\lambda^*, \lambda_{\max}]$ estimated to contain eigenvalues of \mathbf{A}_{fine}

Source of Unstructured Finite Element Mesh: Vertebra

Study failure modes of trabecular Bone under stress

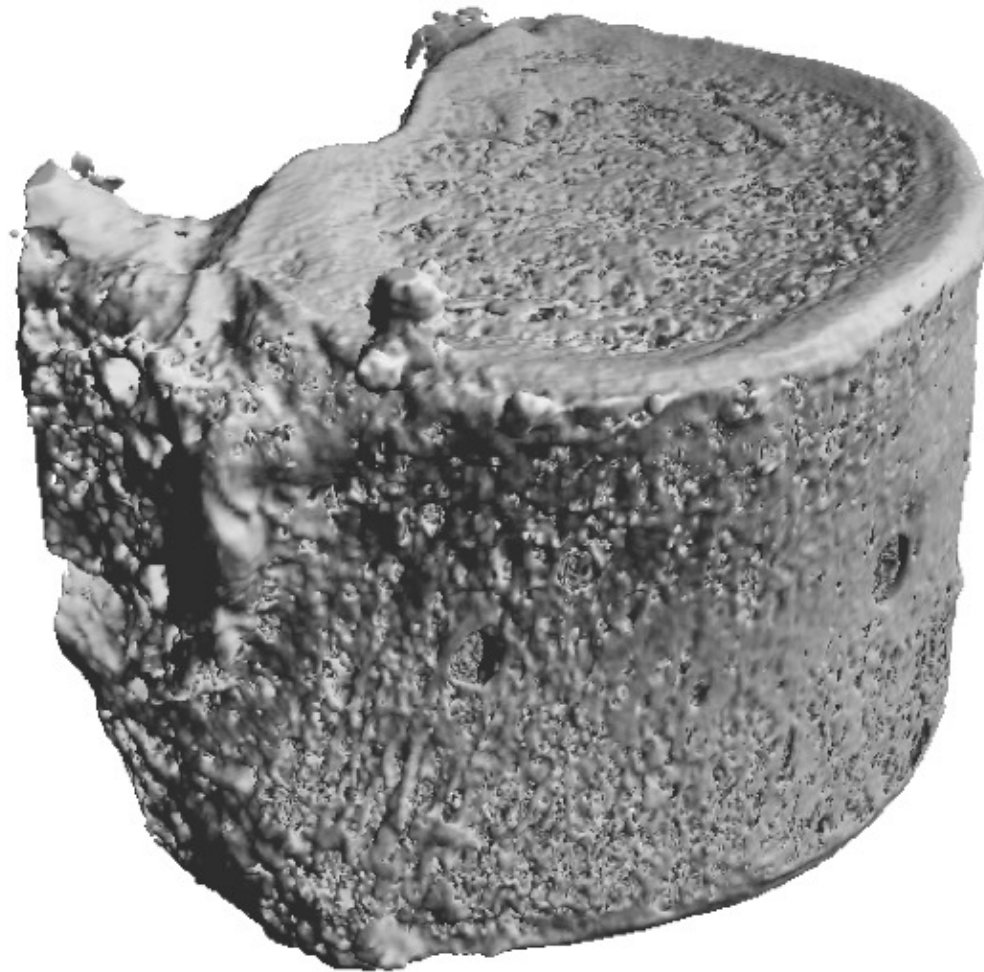

Source: M. Adams, H. Bayraktar, T. Keaveny, P. Papadopoulos, A. Gupta

Methods: μ FE modeling

Mechanical Testing

E , ϵ_{yield} , σ_{ult} , etc.

Source: Mark Adams, PPPL

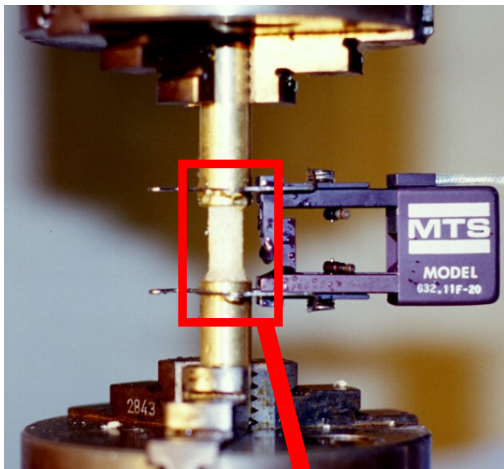

3D image

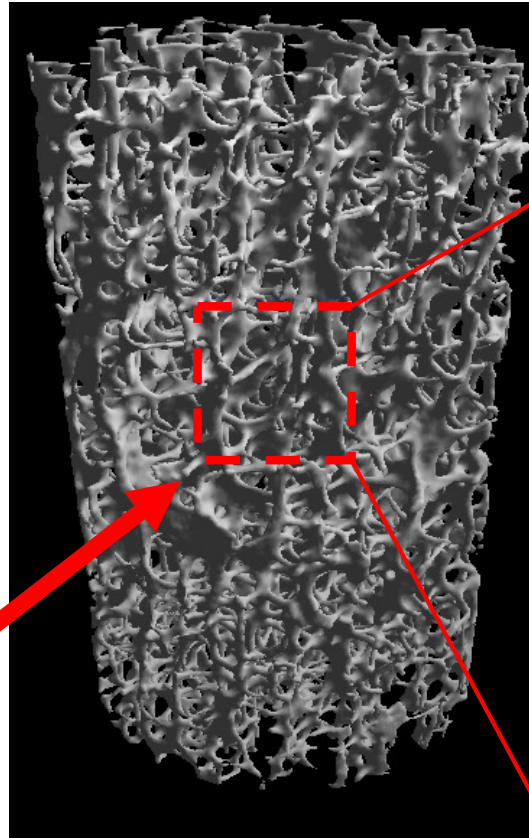

μ FE mesh
2.5 mm cube
44 μm elements

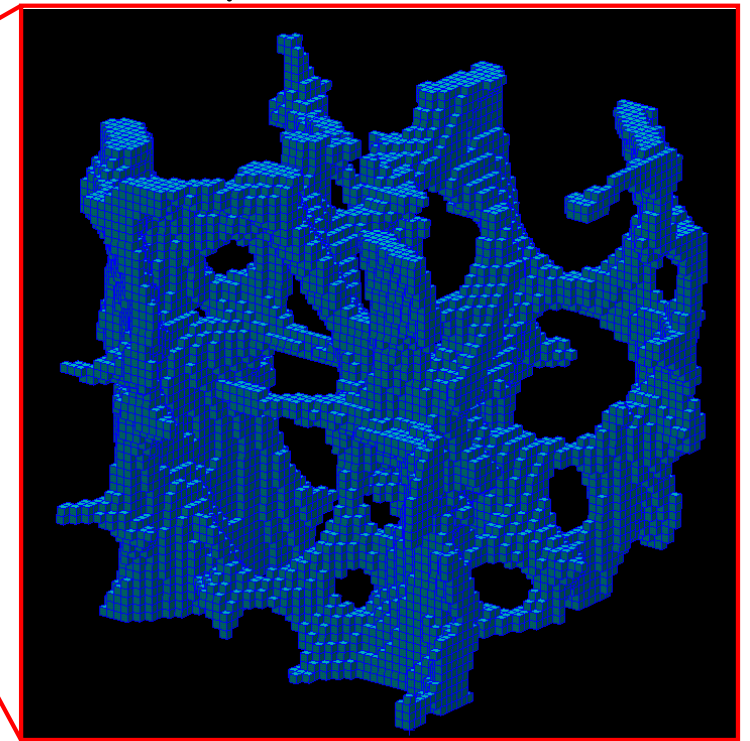

Micro-Computed Tomography
 μCT @ 22 μm resolution

Up to 537M unknowns

Vertebral Body With Shell

- Large deformation elasticity
- 6 load steps (3% strain)
- Scaled speedup
 - ~131K dof/processor
- 7 to 537 million dof
- 4 to 292 nodes
- IBM SP Power3
 - 14 of 16 procs/node used
 - Up to 4088 processors
- Double/Single Colony switch
- Gordon Bell Prize, 2004
- Clinical application to predicting chance of fracture due to osteoporosis

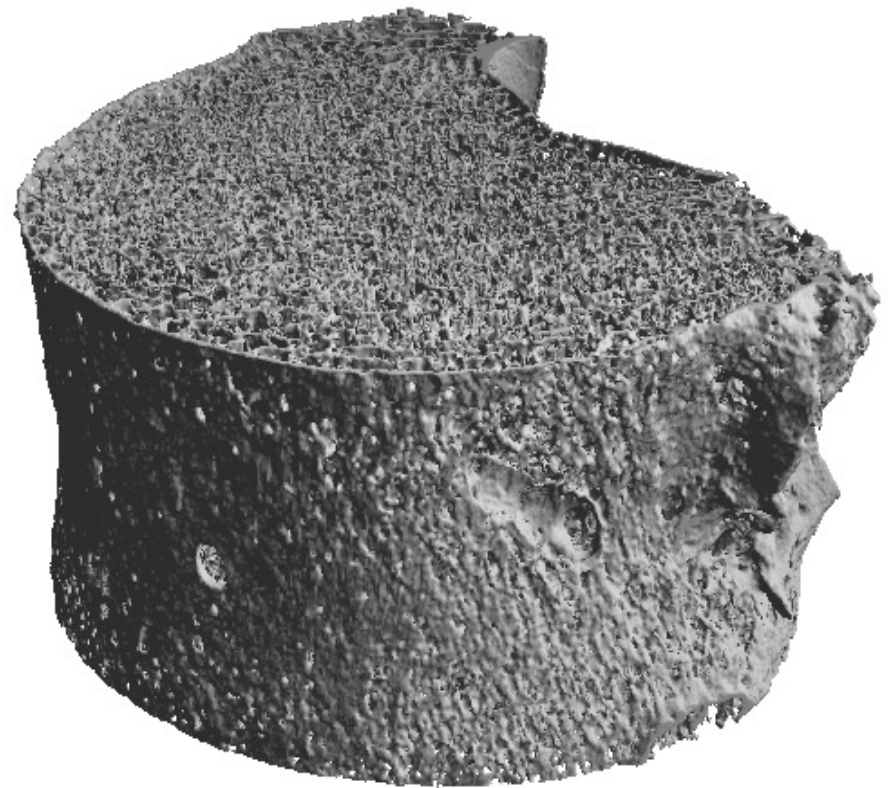

80 μm w/ shell

131K dof / proc (weak scaling) - Flops/sec/proc .47 Teraflops - 4088 processors

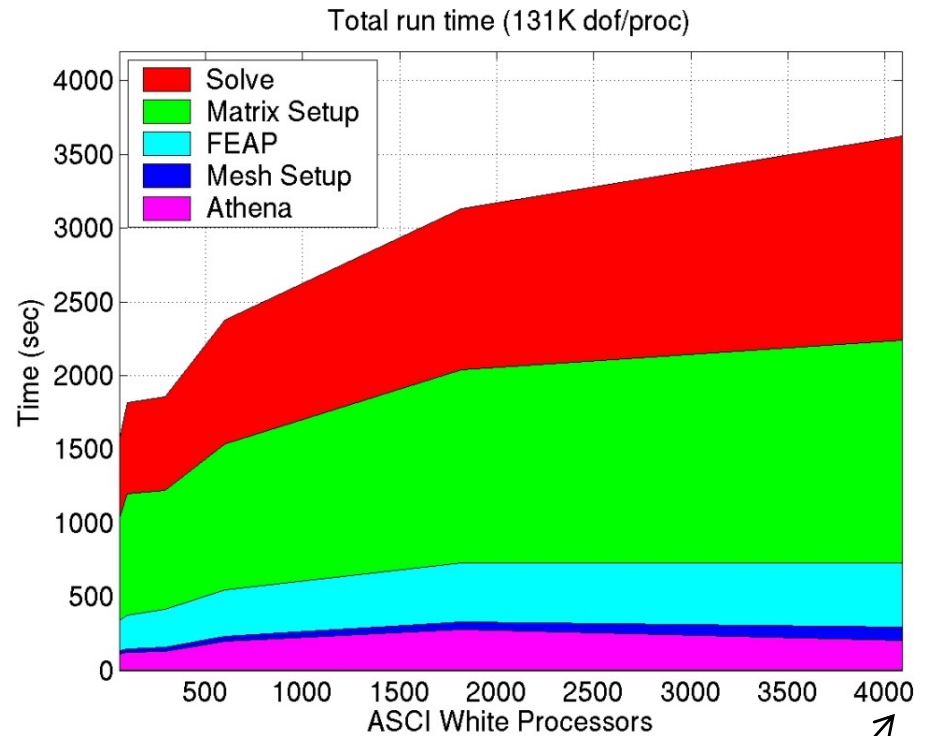
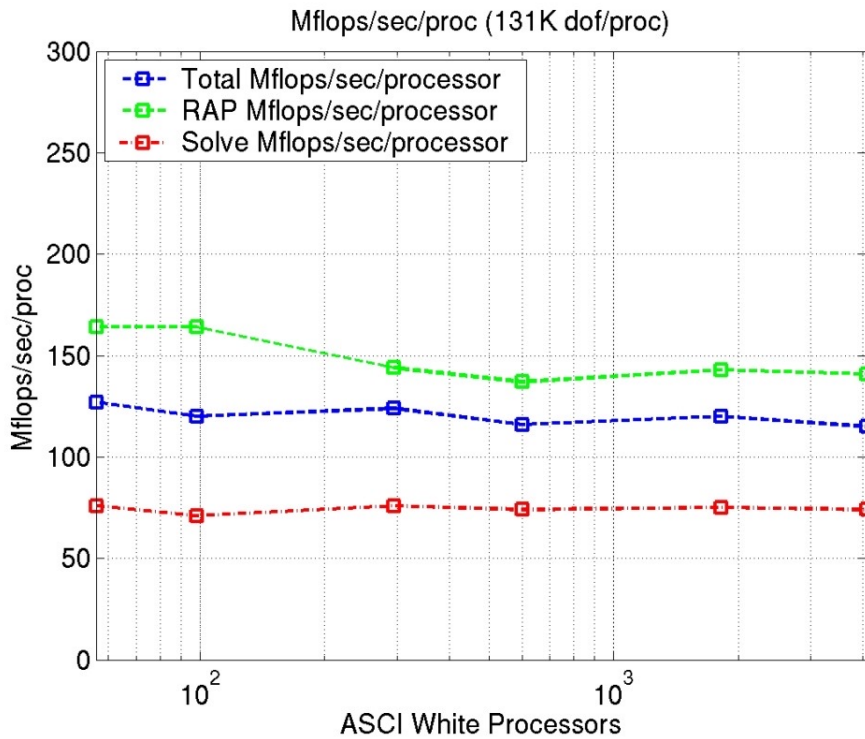

537M dof !

Conclusions

- **Multigrid can be very fast**
 - Provably “optimal” (does $O(N)$ flops to compute N unknowns) for many problems in which one can show that using a coarse grid gives a good approximation
 - Can be parallelized effectively
- **Multigrid can be complicated to implement**
 - Lots of software available (see web page for pointers)
 - PETSc (includes many iterative solvers, interfaces to other packages, Python interface, runs in parallel)
 - ACTS (repository for PETSc and other packages)
 - Offers periodic short courses on using these packages
 - MGNET
 - Sample Matlab implementation for 1D and 2D Poisson
 - See class web page under “Matlab Programs for Homework Assignments”

Extra slides

Parallel 2D Multigrid

- Multigrid on 2D requires nearest neighbor (up to 8) computation at each level of the grid
- Start with $n=2^m+1$ by 2^m+1 grid (here $m=5$)
- Use an s by s processor grid (here $s=4$)

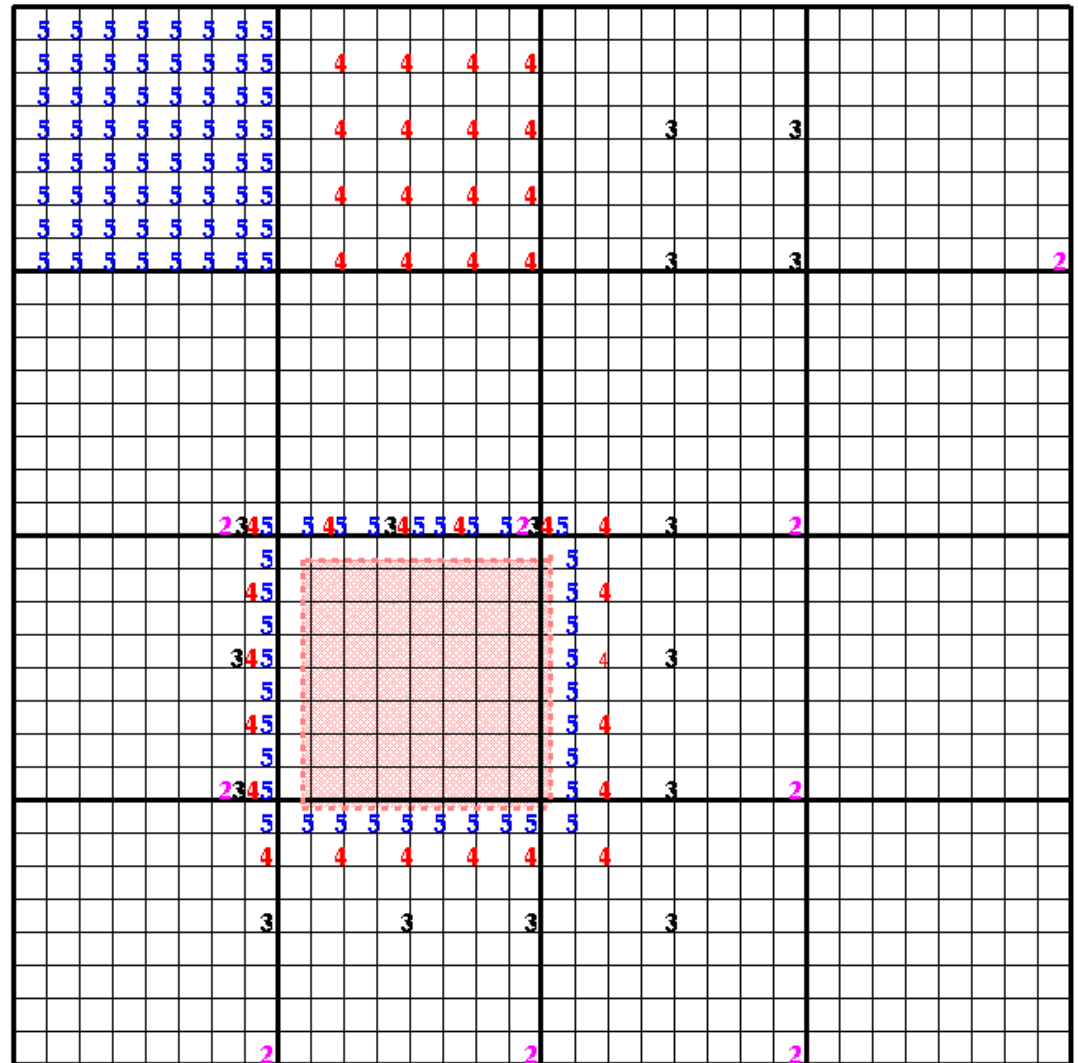

Communication pattern for Multigrid on 33 by 33 mesh with 4 by 4 processor grid
 In top processor row, grid points labeled m are updated in problem $P(m)$ of multigrid
 Pink processor owns grid points inside pink box
 In lower half of graph, grid points labeled m need to be communicated to pink processor
 in problem $P(m)$ of multigrid

Performance Model of parallel 2D Multigrid (V-cycle)

- Assume 2^{m+1} by 2^{m+1} grid of points, $n = 2^{m+1}$, $N = n^2$
- Assume $p = 4^k$ processors, arranged in 2^k by 2^k grid
 - Processors start with 2^{m-k} by 2^{m-k} subgrid of unknowns
- Consider V-cycle starting at level m
 - At levels m through k of V-cycle, each processor does some work
 - At levels $k-1$ through 1 , some processors are idle, because a 2^{k-1} by 2^{k-1} grid of unknowns cannot occupy each processor
- Cost of one level in V-cycle
 - If level $j \geq k$, then cost =
 - $O(4^{j-k})$ Flops, proportional to the number of grid points/processor
 - + $O(1) \alpha$ Send a constant # messages to neighbors
 - + $O(2^{j-k}) \beta$ Number of words sent
 - If level $j < k$, then cost =
 - $O(1)$ Flops, proportional to the number of grid points/processor
 - + $O(1) \alpha$ Send a constant # messages to neighbors
 - + $O(1) \beta$ Number of words sent
- Sum over all levels in all V-cycles in FMG to get complexity

Comparison of Methods (in $O(\cdot)$ sense)

	# Flops	# Messages	# Words sent
MG	$N/p + \log p * \log N$	$(\log N)^2$	$(N/p)^{1/2} + \log p * \log N$
FFT	$N \log N / p$	$p^{1/2}$	N/p
SOR	$N^{3/2} / p$	$N^{1/2}$	N/p

- **SOR is slower than others on all counts**
- **Flops for MG and FFT depends on accuracy of MG**
- **MG communicates less total data (bandwidth)**
- **Total messages (latency) depends ...**
 - This coarse analysis can't say whether MG or FFT is better when $\alpha \gg \beta$

Practicalities

- **In practice, we don't go all the way to $P^{(1)}$**
- **In sequential code, the coarsest grids are negligibly cheap, but on a parallel machine they are not.**
 - Consider 1000 points per processor
 - In 2D, the surface to communicate is $4\sqrt{1000} \approx 128$, or 13%
 - In 3D, the surface is $1000^{2/3} \approx 500$, or 50%
- **See Tuminaro and Womble, SIAM J. Sci. Comp., v14, n5, 1993 for analysis of MG on 1024 nCUBE2**
 - on 64x64 grid of unknowns, only 4 per processor
 - efficiency of 1 V-cycle was .02, and on FMG .008
 - on 1024x1024 grid
 - efficiencies were .7 (MG Vcycle) and .42 (FMG)
 - although worse parallel efficiency, FMG is 2.6 times faster than V-cycles alone
 - nCUBE had fast communication, slow processors

Multigrid on an Adaptive Mesh

- For problems with very large dynamic range, another level of refinement is needed
- Build adaptive mesh and solve multigrid (typically) at each level

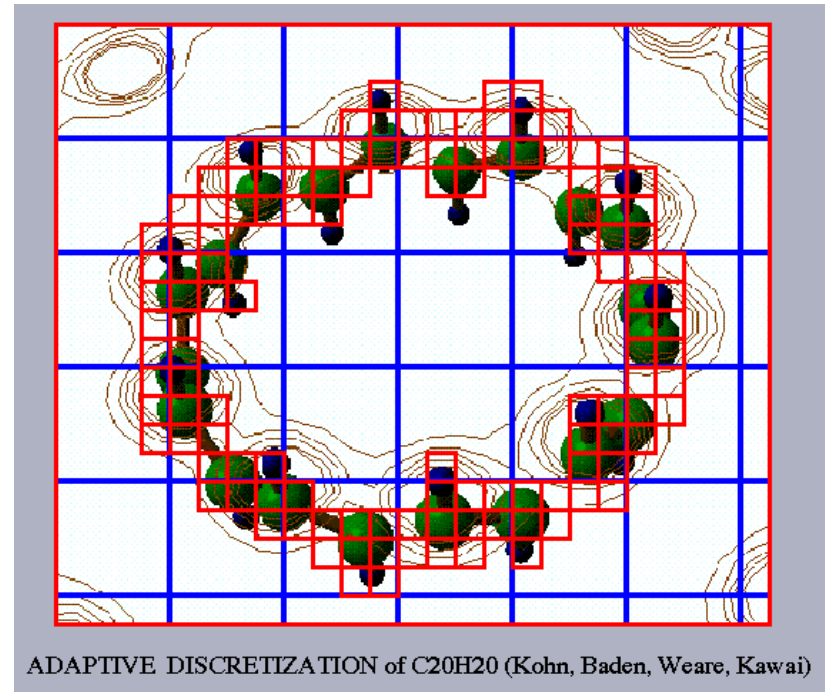

- Can't afford to use finest mesh everywhere

Multiblock Applications

- **Solve system of equations on a union of rectangles**
 - subproblem of AMR

◦ E.g.,

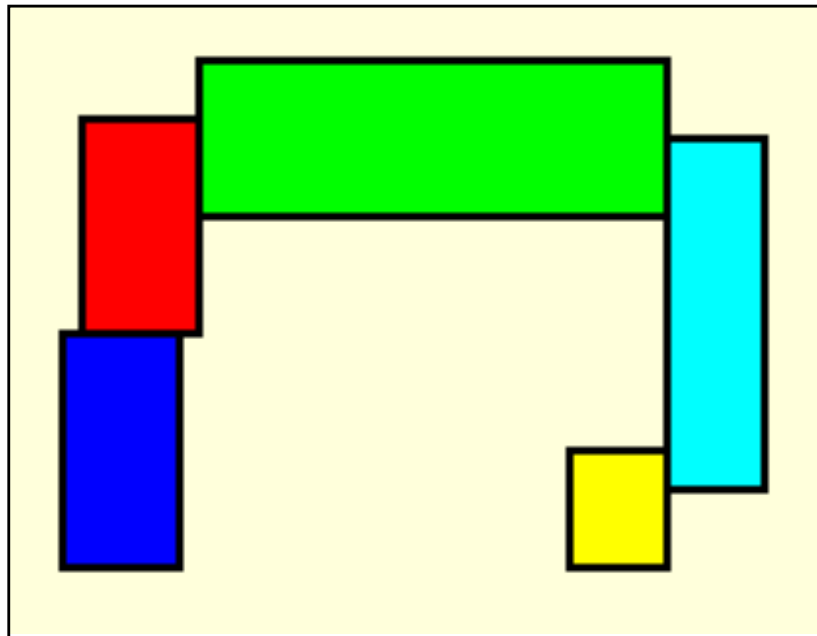
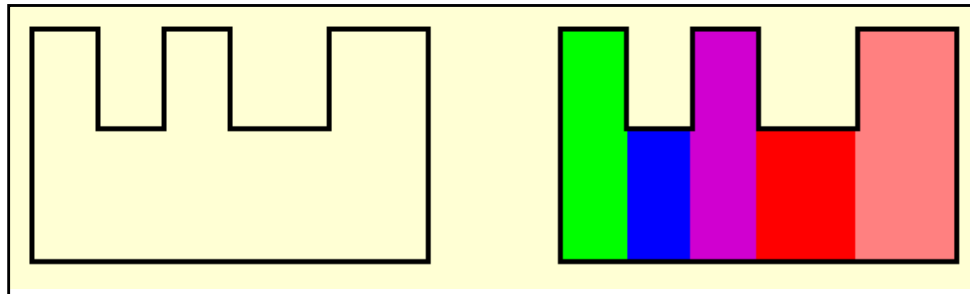

Adaptive Mesh Refinement

- Data structures in AMR
- Usual parallelism is to assign grids on each level to processors
- Load balancing is a problem

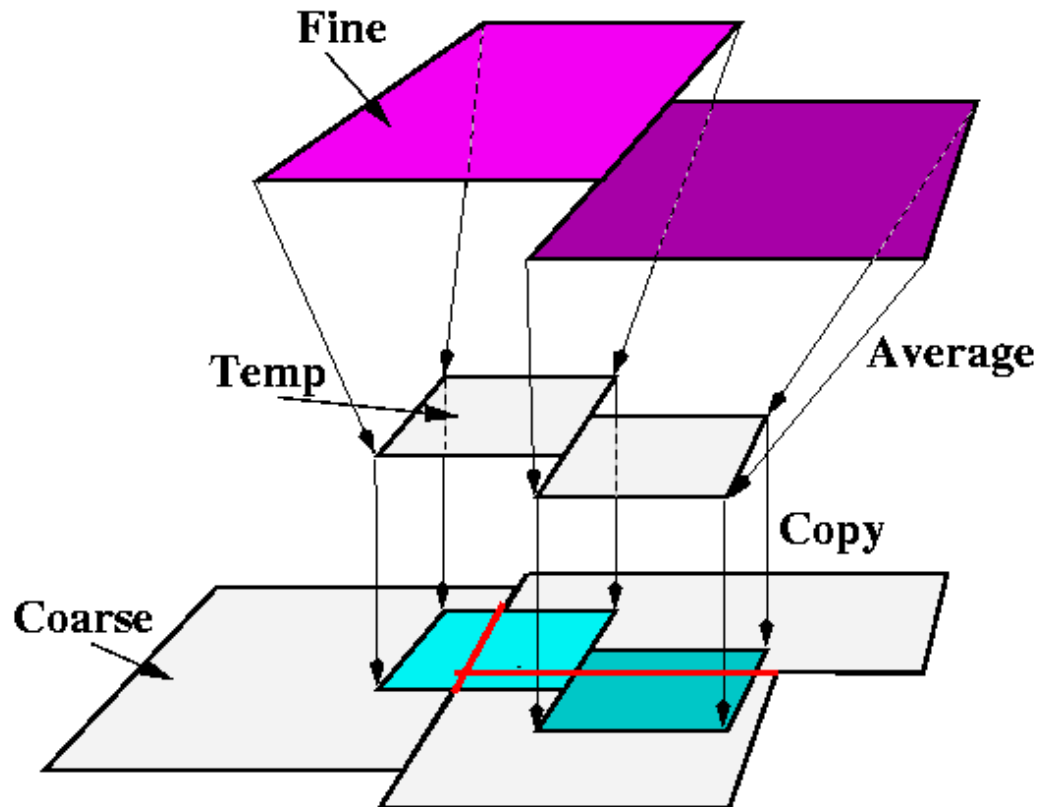

Support for AMR

- Domains in Titanium designed for this problem
- Kelp, Boxlib, and AMR++ are libraries for this
- Primitives to help with boundary value updates, etc.

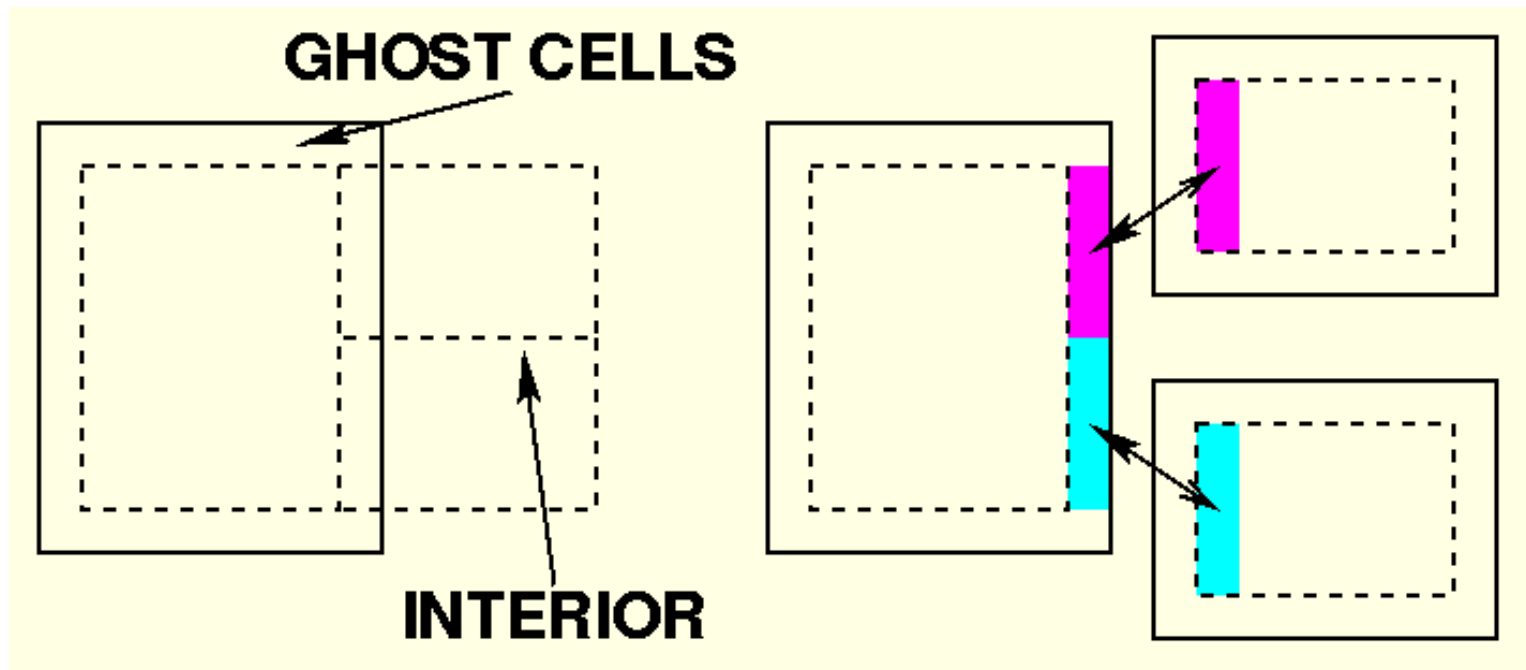

Multigrid on an Unstructured Mesh

- Another approach to variable activity is to use an unstructured mesh that is more refined in areas of interest
- Adaptive rectangular or unstructured?
 - Numerics easier on rectangular
 - Supposedly easier to implement (arrays without indirection) but boundary cases tend to dominate code

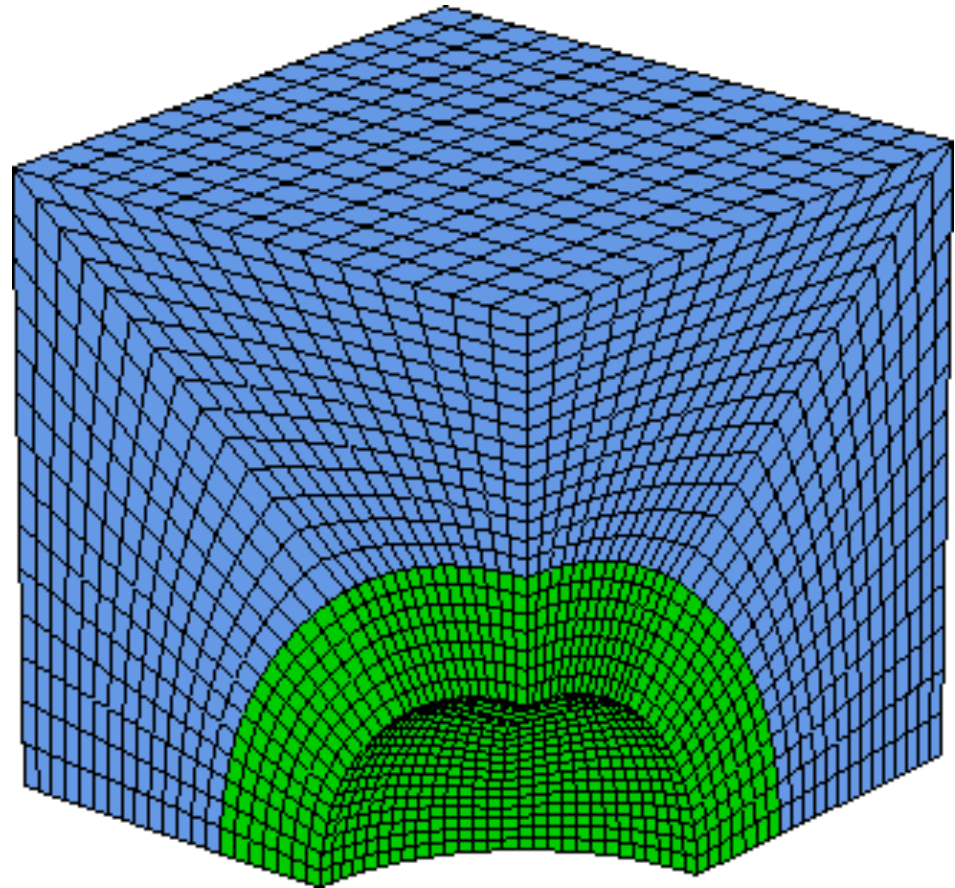

**Up to 39M unknowns on 960 processors,
With 50% efficiency (Source: M. Adams)**