

How Blabber-Mouth German U-Boats got Themselves Sunk in World War II

W. Kahan, Prof. Emeritus,
Depts. of Math., and of Elect. Eng. & Computer Sci.
University of California, Berkeley CA 94720-1776

Prepared for presentation to ...
the E.E.&C.S. Undergrad.Honor Society *HKN* on Tues. 28 Feb. 2006,
and the U.C.B. Kosmos Club, Mon. 1 Nov. 2010.

Posted on <<http://www.eecs.berkeley.edu/~wkahan/BlaUboat.pdf>>

Abstract: When World War II ended in 1945, I was a very lucky Canadian 12-year-old deeply indebted to a generation who fought that war for me. Afterwards some of them became my teachers, professors, colleagues and friends whose technological interests and activities overlapped mine. And I became acquainted too with some who had fought against us. Recounting their stories before they fade from aging memories repays a little towards a debt that can never be repaid fully. Besides, some of their stories reveal what were then close-kept technological and military secrets; now they are interesting arcana.

Contents:

p. 3	When and where did World War II begin?
5	Axis airforces and German U-Boats earn their reputations
6	How did the Allies finally overcome the U-Boats by 1945 ?
7	German Technological and Military Pre-eminence in 1939
9	An example: Duds (Nonexploding torpedos)
12	Robert Alexander Watson Watt 1892 - 1973
13	The Radio Spectrum before World War II
14	Two Calamities attributable to Lapses in <i>hf</i> Radio Communication
13	How does a Magnetron work?
17	Radar Screens
18	What are <i>Chaff</i> , <i>Window</i> , ... ?
19	The Death of U-848
21	Captured U-505
23	Dönitz demanded that U-Boats blab
24	How does Huff-Duff work?
25	Sonobuoys deployed in late 1944
26	The story of Werner H.
27	<i>Metox</i> and <i>Naxos</i> vs. Radar
29	U-Boat Bases seemed Impregnable, until ...
31	Willful Destruction of Cities
32	Technically Adept Manpower comes into Critically Short Supply
33	The <i>Rotterdam Gerät</i> (Apparatus)
34	Proximity Fuzed Anti-Aircraft Shells: <i>VERY SECRET</i> among secrets kept
37	Why should people who like to kill be the only ones who know how?
38	What should you remember most about World War II ?
39	Books

When did World War II begin ? Depends on where you were.

Not on Sun. 7 Dec. 1941,

“— a date that shall live in infamy” , (F.D.R.)

when the Imperial Japanese Navy’s carrier-borne aircraft sank American battleships at anchor in Pearl Harbor, Hawaii, just before declaring war.

Fascist governments had been waging wars on-and-off for over ten years, encouraged by the acquiescence of populations not yet victimized.

Fascism: Government by whoever holds the power to coerce the governed, regardless of their consent. Fascist governments eliminate their opponents.

Criminality: Take whatever is to be taken; disregard or eliminate opponents.

What’s the difference?

After the great Depression began in 1929, holders of vast wealth supported right-wing fascist mobs, pretending they would protect property rights, against left-wing Democrats, Socialists, Labor organizers and Communists who were all labelled “Communist” and “Bolshevik” indiscriminately and were often “Disappeared” or simply assassinated, often with police or military connivance.

A Chronology of Fascist Aggression:

- 1922 Fascists led by Mussolini take over Italian government by force.
- 1931 Japan's army usurps Manchuria, assassinates Japanese opponents.
- 1933 Hitler-led NAZIs elected in Germany, launch "2000 year Reich".
- 1935 Italy invades Abyssinia (Ethiopia); League of Nations impotent.
- 1936 Hitler remilitarizes Rhineland; France and Britain back down.
Spanish civil war: Fascist Franco invades vs. elected Republicans.
Fascist Italy & Germany help Franco, Russia helps Republicans,
others pretend "neutrality", embargo arms to Republicans.
- 1937 Japan's army invades coastal China, "Rape of Nanking" atrocities.
- 1938 Germany annexes Austria, Czech Sudetenland; Fr. & Br. cave in.
Hitler says "We want no Czechs". "Peace in our time" — Chamberlain
- 1939 Hitler "protects" all Czechoslovakia from Britain; threatens Poland.
German & Russian Non-Agression Pact, agree to divide up Poland.
Germany invades Poland; Russia occupies its former territories.
France & British Empire (incl. Canada) declare war on Germany
- 1940 Germany takes Norway, Denmark, Holland, Belgium and France;
German bombers blast and burn London, Coventry,
- 1941 Italy occupies Albania (just across the Adriatic); stopped in Greece.
Germany takes Yugoslavia & Greece; then surprise-attacks Russia.
Japan takes Indo-China, attacks Pearl Harbor, Philippines,

By the time the U.S.A. was drawn into World War II in 1941,
***Axis* airforces had earned their reputations ...**

Year	Fascist Italy bombed ...	Imperial Japan bombed ...	Nazi Germany bombed ...
1931		Manchurian villages	
1935-6	Addis Ababa (Ethiopia)		Madrid (Spanish "Civil" war)
1937-8	Barcelona	Shanghai, Nanking, Hankow, Canton, Swatow, Amoy	Durango, Guernica, Bilbao.
1939			Warsaw & other Polish towns
1940			Freiburg †; Rotterdam; London, Liverpool, Coventry, Glasgow, Bristol, ...
1941 - 1942	villages in Albania and Macedonia	Pearl Harbor, Singapore, Hong Kong	..., Southampton; Belgrade. Leningrad (now St. Petersburg) Kiev, Sebastopol, Moscow

† On 10 May 1940 three *Luftwaffe* bombers missed their assigned target, a French airfield near Dijon, by 132 miles and hit Freiburg in southwest Germany, whose propagandists blamed the British.

German submarines, operating since 3 Sept. 1939, earned reputations too; by Dec. 1941 they had sunk about 1020 ships for a loss of only 66 U-Boats.

Among the ships sunk were about a dozen British warships, including a battleship in its harbor; and an aircraft carrier, cruisers and destroyers at sea. But over a thousand of the ships sunk were unarmed merchantmen and tankers.

The advantage see-sawed several times as WW-II wore on. In its last year, Germany lost over 270 U-Boats while sinking fewer than half that many Allied ships. U-Boats failed to stop troopships from crossing first the Atlantic and then the English Channel when the liberation of France began in June 1944.

By war's end in mid 1945, German U-Boats had sunk \approx 3000 Allied ships, less than 5% of the ships built during the war, only one of them a loaded troop transport. 783 of 1170 U-Boats launched had been sunk, mostly by American, British & Canadian forces.

Of about 37,000 Germans who went to sea in U-Boats, about 28,000 never returned. But first they killed over 40,000 Allied seamen among whom only a few thousand were naval personnel.

How did the Allies finally overcome the U-Boats by 1945 ?

Production: American shipyards launched far more ships than U-Boats could sink.

Escorts: Corvettes and (best of all) escort-carriers' aircraft chased U-Boats.

Decryption: Broken *Enigma* ciphers betrayed U-Boats' assigned missions.

Electronics: Radar, *Huff-Duff* and Sonobuoys exposed U-Boats' locations at sea.

Bombing Oil Refineries: Fuel shortages crippled both sorties and crew training.

German Overconfidence: Germans never caught up with Allied Radar, nor caught on to *Huff-Duff* and decryption.

We shall look at some of the technical details:

In 1939 Germany started World War II in Europe with

Technological Pre-eminence: Germany had the best ...

- steel production (from Swedish ore) and metallurgy, esp. ...
 - armor plate & guns \approx 1/2 the weight of British equivalents;
 - e.g., German 11” naval gun bettered British 13”;
 - German 88 mm. Anti-Aircraft/Anti-Tank gun unsurpassed.
- machine tools, and apprenticeship training for mechanics.
- optics for cameras and for gunnery range-finders.
- piston engines for aircraft, cars, boats, tanks, trucks (*but too few*).
- turbo-jet engines under development for aircraft; flew first in 1943.
- steam turbines (most powerful but failure prone) for fastest warships.
- chemical technology: synthetic oil and rubber, poison (nerve-) gas, explosives, and “shaped charges” to puncture armor, Sulfa drugs to inhibit infection of wounds.
 - (*But no Penicillin nor DDT, nor Blood Plasma.*)
- physics: first to observe nuclear fission and predict chain reaction.
- electrotechnology: reliable arc-welding, motors, lamps, radios, TV !
 - military communications, listening posts, direction-finding,
 - secure high-volume encipherment (ENIGMA), wire-recording,
 - Radar: *Seetakt* (80 cm.) for warship gun-laying,
 - Würzburg* (50 cm.) for anti-aircraft gunnery,
 - Freya* (2.4 m.) for early (75 mi.) detection of aircraft.
 - (*But no organization to convey warnings promptly.*)

1939 German technological pre-eminence continued; it had the best ...

— tanks: most had radios and guns far better than British, and went faster.

(Some French and Russian tanks were better armored but lacked good radios.)

— fuel injected aircraft engines (not carburetted) — could fly inverted.

— aircraft: Commercial airline service started in Germany, in 1918!

(Hitler used *Lufthansa* during political campaigns in 1930.)

ME 109 fastest fighter; H-P wing-slats lowered landing speed

... but *its narrow undercarriage loses more 109s to landing accidents than to combat until 1944.*

JU 88 fastest bomber, also served as night-interceptor.

FW 200 Condor longest range reconnaissance/bomber.

JU 87 STUKA dive-bombed ahead of onrushing panzer div'ns.

(But no self-sealing fuel tanks nor droppable fuel tanks; radios not vhf.)

— optical- and radar-directed naval guns accurate beyond 20 miles.

— heavy cruisers: 12,000-ton electro-welded “pocket battleships” *Lützow*, *Graf Spee*, *Adm. Scheer*, ... outgunned or outran their opponents.

— 52,000 ton battleships *Bismarck* and *Tirpitz* would soon do likewise, their heavy armor nearly impervious to British gunfire and torpedos.

27 May 1941: After battleships' shells wrecked its guns, many torpedo hits were needed to sink *Bismarck*.

— rockets, flying bombs, V-1 cruise missile, V-2 ballistic missile (1944).

German Soldiers were the World's Best-Trained:

- Resourceful officers kept forward, well equipped with radios.
- Germans continued fighting under sergeants if officers were lost, unlike British, French, Italians, Poles, Russians,

An example: **Duds** (Nonexploding Torpedos)

- 1/3 of Germans' torpedos were duds for only 8 mos. 1939-40 ;
- 2/3 of Americans' torpedos were duds for over 20 mos. 1941-43 ;
- but all Japanese "Long Lance" torpedos worked superbly. ...

Torpedos carried in submarines were propelled by one of ...

- Compressed air & alcohol burned to spin a steam turbine.
 - German: range 2 mi. @ 40 knots.
 - American: range 3 mi. @ 46 knots or 7 mi. @ 25 knots.
 Betrayed by wake formed by surfacing bubbles of nitrogen from exhaust.
- Electric motor driven by Lead-Acid "storage" batteries like a car's.
 - German: range 4 mi. @ 30 knots.
 - American: range 2 mi. @ 30 knots.
 Wakeless but slow. Recharging on stand-by vented flammable hydrogen gas.
- Compressed oxygen & kerosene burned to spin a gas turbine.
 - Japanese: range 11 mi. @ 50 knots or 30 mi. @ 36 knots.
 Almost wakeless. Carried 1/2 ton explosive warhead vs. others' 1/3 ton.

One blew the bow off Bob Gregory's destroyer at Guadalcanal one night. Miraculously it limped back to Hawaii. Japanese Navy excelled at night fighting until American Radar bested them. Independently developed Japanese Radar became almost as good but too scarce to matter much.

Why were torpedos so often duds ?

Torpedos exploded on Contact, or when Magnetic field changed abruptly.

American contact exploders jammed on direct hits for two years !

American steam torpedos ran too deep for one year.

American electric torpedos had such unreliable guidance that two American submarines were sunk in the Pacific by their own electric torpedos circling back !

Magnetic exploders, intended to explode as the torpedo passed under the target's keel, were thought to offer three advantages:

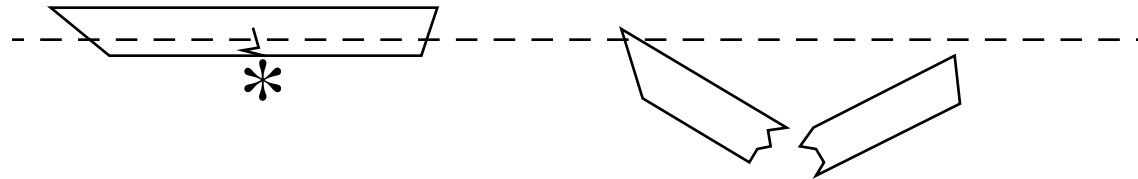

- Breaking a ship's keel and holing its bottom sank it more surely. (Maybe)
- No other way past side-armored hulls and bulges of heavy warships.
- Usable at acute angles, like *Bow Shots* on oncoming destroyers.

But nobody got them to work reliably during WWII, though British and Germans came close: $\approx 25\%$ duds. Americans stopped trying by 1944.

In Nov. 1939 a German magnetically-detonated mine dropped in tidal flats was recovered by the British who figured it out and then “de-Gaussed” their ships to largely thwart magnetic mines and torpedos. All Allies copied this technique.

- 1/3 of Germans' torpedos were duds for 8 mos. 1939-40.
- 2/3 of Americans' torpedos were duds for over 20 mos. 1941-43.

Why were Germans so much quicker than we Allies to eliminate duds?

Different Mental Attitudes:

German: “A German officer never misses.”

Amer./Brit.: “Our officers always have excuses.”

And other reasons ...

American ordnance experts *simulated* (not *tested*) torpedo strikes, under-estimating impacts and failing to detect defects in detonators. Their excuse: “Torpedos are *too expensive* to waste on real tests.”

But German leaders expected to win the war by 1943, so they undervalued much of their technological manpower.

Thus the Allies turned Electronics into a great advantage.

Robert Alexander Watson Watt 1892-1973

Scottish engineer — Radio & Meteorology

- 1920s: His apparatus to locate far-distant lightning helps warn aircraft away from thunderstorms.
 - 1935: Supdt. of Radio Dept. of England's National Physical Lab., he passes Air Ministry request for a “Death Ray” to his staff, who counter-propose detecting aircraft by reflected radio waves. He writes up the proposal to become Britain’s “Father of Radar”. At the same time, similar ideas are being explored in America, France, Germany, Holland, Italy, Japan, and Russia, all very secretly. Only Watson Watt’s proposal attracts substantial governmental support then.
 - 1939: British integrate Watson Watt’s 10 m. Radar chain with *vhf* radios in fighter aircraft. German Zeppelin LZ30 detects no radiation from British Radar turned off! German 50 cm. Radar serves mainly to find range for Naval guns. Germany starts WWII, tracks British bombers on its Radar, but expects to win war before having to deploy Radar defensively.
 - 1940: Birmingham U. physicists Randall & Boot invent *Magnetron*: 15 KW @ 10 cm. Warned by Watson Watt’s Radar, British defy German efforts to bomb Britain into submission. His thunderstorm-location inspires H.F.D.F to locate U-Boat transmissions in a few seconds. Britain sends magnetron, penicillin and other inventions secretly to U.S. to mass-produce them.
 - 1941: Hitler bogs Germany in war with Russia, and with U.S. after Japan attacks Pearl Harbor.
 - 1942: Advanced at M.I.T. and Bell Labs, and mass-produced in U.S. & Canada, Magnetron-based 10 cm. Radar plus H.F.D.F. gives Allied naval and air forces decisive advantages.
- ... Knighted *Sir* Robert A. Watson-Watt.
- 1951: Of paltry £ 87,950 (\approx \$5 million today) awarded to seven British Radar pioneers, Sir Robert grabs £ 52,000 and uses it to found a consulting firm to advise British industry how to *organize* its research.
 - 1952: Sir Robert divorces Margaret to marry gorgeous widow Jean Drew and move to Canada where she must care for an ailing relative. He founds *Adalia Ltd.* consulting in Toronto, Montreal, New York.
 - 1954: *Adalia* simulates computerized reservation system for Trans-Canada Airlines. (My summer job.) *Adalia* tries to patent color printing processes to hold up Time-Life, but goes broke in a few years.
 - 1964-73: Jean dies. Sir Robert remarries, gets Alzheimer's. 3rd wife dies. Sir Robert sent to RAF nursing home in Scotland, dies aged 81.

The Radio Spectrum before World War II

Almost all 1940 radios' vacuum tubes had elements too widely spaced and leads too long to amplify signals well much beyond 30 MHz (below 10 m). Up to that time the accessible radio spectrum had been partitioned roughly thus:

	<u>Frequencies / Wave</u>	<u>... Around</u>	<u>Service</u>
<i>mf</i>	Medium / Medium	1 MHz / 300 m	Local AM Broadcasts
<i>hf</i>	High / Short	10 MHz / 30 m	Long-Distance Communication
<i>vhf</i>	Very High / ...	100 MHz / 3 m	Amateur, Research, Radar

Signal propagation much beyond line-of-sight depends upon absorption or reflection by the *Ionosphere*. Ionized by sunlight, this layer of air lies above 60 miles altitude by day, 170 miles by night. Its variability afflicts *hf* radio communication, which suffers from silent *Skip Zones* roughly 100 – 200 miles from the transmitter, and from *static* (interference) emanating from distant sources both natural (lightning) and man-made. Rarely do *vhf* signals propagate far beyond line-of-sight, so they're comparatively free from noisy *static*.

R.A. Watson Watt insisted that British fighter aircraft be equipped in 1939 with *vhf* radios for communication with each other and with ground controllers informed by Radar. This sped up development and production of “miniature” (thumb-sized and smaller) vacuum tubes pioneered by Philips in Holland.

In the summer of 1940, during the *Battle of Britain* against German bombers, British pilots enjoyed the advantage of clear and efficient communications that the Germans came to appreciate only after they had lost that battle.

Two Calamities attributable to Lapses in *hf* Radio Communication

14 May 1940: German bombers set undefended Rotterdam ablaze.

It was widely believed during WWII that Holland capitulated because 30,000 Dutchmen were killed.

Actually the Dutch army and airforce had fought well for four days, but isolated from their allies and outnumbered. Shortly after noon a hundred *Luftwaffe* bombers took off to support dwindling German airborne troops who had siezed the Willems bridge across the Maas river in central Rotterdam to clear the way for a *Panzer* division held up by unexpectedly stiff resistance. Meanwhile exhausted Dutch defenders acceded to the Germans' ultimatum demanding surrender by 6 pm. Radio signals recalling the bombers failed to reach them; at 3 pm. 57 of them dropped 97 tons of bombs before flares sent up through smoke and haze signalled the rest to desist. As such things go the bombing was accurate, but it ignited a warehouse full of butterfat. Despite substantial German aid, Dutch firemen could not contain the fire until it had consumed the crowded old core of Rotterdam. About 1,000 residents were killed, but a panicky member of the Dutch government released the figure of 30,000. German authorities let the inflated figure stand thinking that it enhanced the *Luftwaffe's* reputation; besides, who'd have believed the truth from them?

7 Dec 1941: Japanese aircraft sink American battleships in Pearl Harbor.

The previous day a secret message tantamount to a declaration of war had been sent to the Japanese Embassy in Washington with instructions for its delivery to the U.S. Secretary of State an hour before the scheduled attack. Delivery was delayed past that hour by an inept translator-and-typist. Meanwhile U.S. Army cryptanalysts had intercepted the message and inferred that an attack was imminent, but not where. Warnings to commanders in the Pacific were delayed first by time spent locating Chief of Staff Gen. G.C. Marshall to authorize the warnings, then by repeated failures to reach Pacific bases by *hf* radio, then by a blunder: An encoded warning sent to Hawaii by undersea cable was not marked "High Priority" so it sat around a while before being delivered during the attack. Delivered two hours earlier, the warning could have alerted the army to the significance of early Radar sightings of approaching aircraft and thus at least halved American casualties; or the warning might have been deemed another of several recent "false alarms" and ignored.

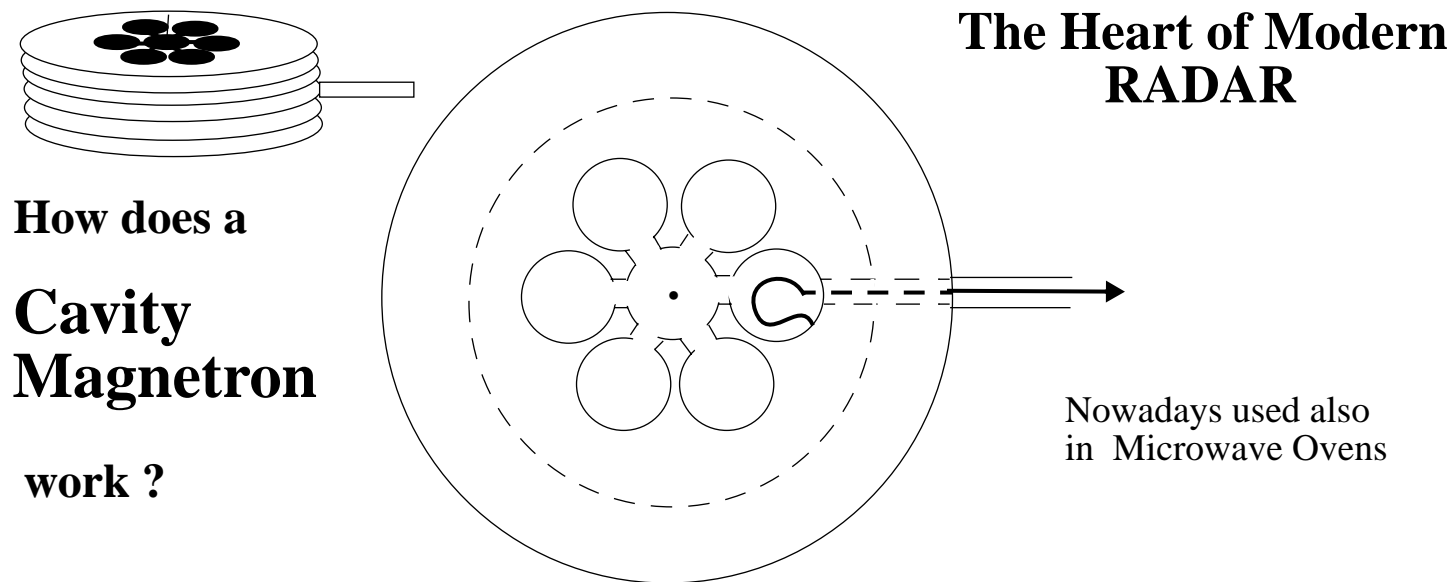

Construction: Starting with a copper cylinder, at least six holes are drilled around and connected to a central hole by slots, all parallel to the cylinder's axis. Cooling fins are cut into the cylinder's sides and a hole drilled there for a rigid coaxial connection to a loop in one of the outer chambers. A coated filament is run down the cylinder's axis. All holes' ends are sealed and a vacuum is established in the chambers. This device is put between the poles of a strong C-shaped magnet whose field runs parallel to the cylinder's axis.

Operation: Electric current heats the cathode filament, emitting electrons attracted to the copper anode held at a high positive voltage – several kilovolts. The magnetic field forces electrons into spirals. Passing the slots, the electrons excite electro-magnetic resonances in the outer chambers much as air blown past a beer-bottle's mouth generates a low-pitch whistle. Adjusting the anode voltage synchronizes the electrons' speed to the resonances, which grow to very high intensity. The loop transfers out some of that microwave energy.

Output: Kilowatts to megawatts at wavelengths of a few centimeters are several orders of magnitude more power at wavelengths one or two orders of magnitude shorter than obtainable from the vacuum tubes of the 1940s. Much higher power at cm. wavelengths were obtained from magnetrons serving in Radar sets invented in Britain in 1940, disclosed to the U.S., and improved and produced here in vast numbers to equip all the Allies in World War II. (Low-power magnetrons in Microwave ovens run continuously at shorter 3 cm. wavelengths resonant with water molecules in foods, heating them.)

At about the same time, the Japanese invented magnetrons for Radar but could not produce many, and kept them secret from their wartime German partners. Their secrecy worked to our advantage.

How Radar works: Every second thousands of microwave pulses several nanoseconds each in duration are focused by an antenna into beams reflected back from ships, aircraft, vehicles, buildings, An echo's delay reveals a target's range in the beam's direction. The shorter the wavelength, the sharper the beam's resolution and/or the smaller the antenna needed. The greater the power, the longer the Radar's reach to smaller targets.

Brief Radar pulses required brief anode voltage pulses (several kilovolts) of closely controlled amplitude and duration. Experience gained with the needed "pulse circuitry", quite different from pre-war analog circuitry, figured again in the war when the British built *Colossus*, the very secret vacuum-tube based electronic computer that helped them decrypt intercepted German radio messages.

...

After the war British military captains joined with Captains of Industry in taking too much personal credit for winning the war, and reverted to pre-war practices, denying opportunities to the young who consequently emigrated to former colonies taking technology with them. Thus Britain lost its hard-won technological superiority and has now become merely a quaint island destination for tourists.

Radar Screens on Cathode Ray Tubes (like old TV screens)

Earliest British (shorn of "Grass"): Vulnerable to *Chaff* / *Window*, / *Düppel* / *Giman-shi*

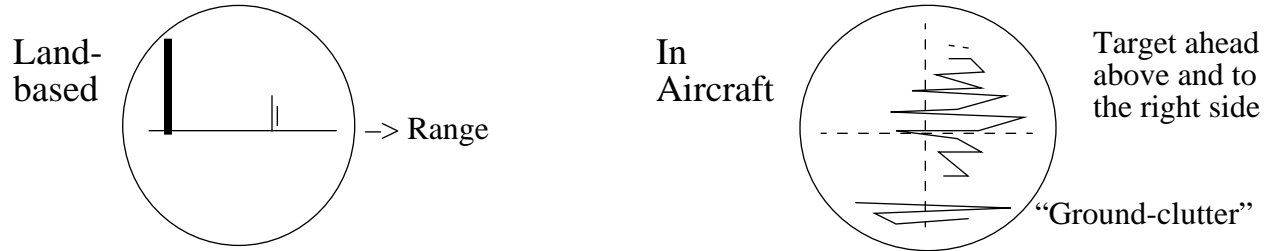

Early American vacuum-tube powered Radar:

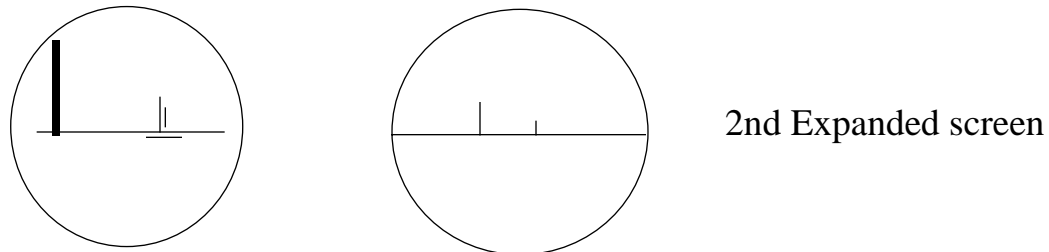

Later Allied PPI ("Plan Position Indicator") using Magnetron-powered centimetric Radar:

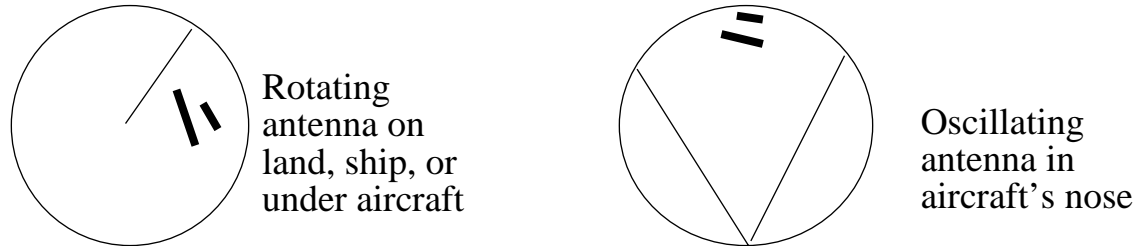

What are ...

<i>Chaff</i>	(British)	:
<i>Window</i>	(American)	:
<i>Düppel</i>	(German)	:
<i>Giman-shi</i>	(Japanese)	:
		... ?

Thin strips of tin-foil cut to lengths resonant with Radar waves, these strips float in the air for over twenty minutes after being dumped from a high-flying aircraft. Then they reflect Radar signals so strongly as to simulate echos from aircraft.

Dumped in quantity, these strips simulate armadas of bombers on Radar screens of ground controllers, who then misdirect intercepting aircraft and anti-aircraft guns against tinfoil while attacking bombers sneak past distracted defences.

Both sides, Allied and Axis, discovered in 1940 how this stuff would ruin their defences, so each decided to keep it secret from the other side by not using it. Hermann Göring went so far as to forbid the *Luftwaffe* to mention or perform research upon the stuff lest spies get wind of it and report back to the British.

In 1943, Allied 10-cm. Radar generated by Magnetrons was deemed to have resolution adequate to distinguish bombers from tinfoil, so it was used to mask attacks upon Hamburg that turned the city's inner core into a vast funeral pyre. This disaster, coming a few months after the defeat at Stalingrad, foreshadowed Germany's fate if it did not stop the war. But the Nazis would not stop.

The Death of U-848: Commissioned 20 Feb. 1943. Lost 5 Nov. 1943.



U-848 :

Type IX-C
Long-Range
Submarine
on its way to
Indian Ocean.

Sunk with
all hands.

Sunk by 5 bombers (3 B-24, 2 B-25) from a base a few hundred miles away on Ascension Island in the middle of the South Atlantic. Strafing kept crew from four 2-cm. flak guns.

How did the Aircraft know where to find the U-Boat ?

How was U-848 located by its attackers?

- Allies Eavesdropped on German Coded & Encrypted Radio Traffic.
- HFDF Pointed to U-Boats transmitting compressed radio messages.

.....

Naval Codes: Frequent messages' abbreviations listed in a Code Book.

Encryption: U-Boats had most intricate versions of *ENIGMA* machine.

Barely before German invasion, Polish mathematicians passed to British a tedious way to decrypt German Military ENIGMA. Mechanized decryption let British read some German messages within a few days. RN capture of U-110 near Iceland in May 1941 exposed keys & codes to British, who let U-110 sink in sight of its crew to persuade them that nothing of value had been recovered. Germans changed keys & codes several months later. Three RN swimmers to captured U-559 near Port Said in Oct. 1942 retrieved new keys & codes from foundering sub, which sank with two swimmers. Several months later, Germans changed keys & codes again, but used old codes for weather reports letting British and Americans decrypt many other messages sent in new codes.

USN captured U-505 a few hundred miles south of Canary Islands in June 1944 and towed it decks awash to Bermuda. Its crew was interned *incommunicado* (no Red Cross) to keep secret the recovery of an ENIGMA and code books. These ensured that Allies would know most U-Boats' assignments within a day of transmission until war's end.

Attaching a Tow-Line to Captured U-505, 4 June 1944



Where is U-505 Now ?

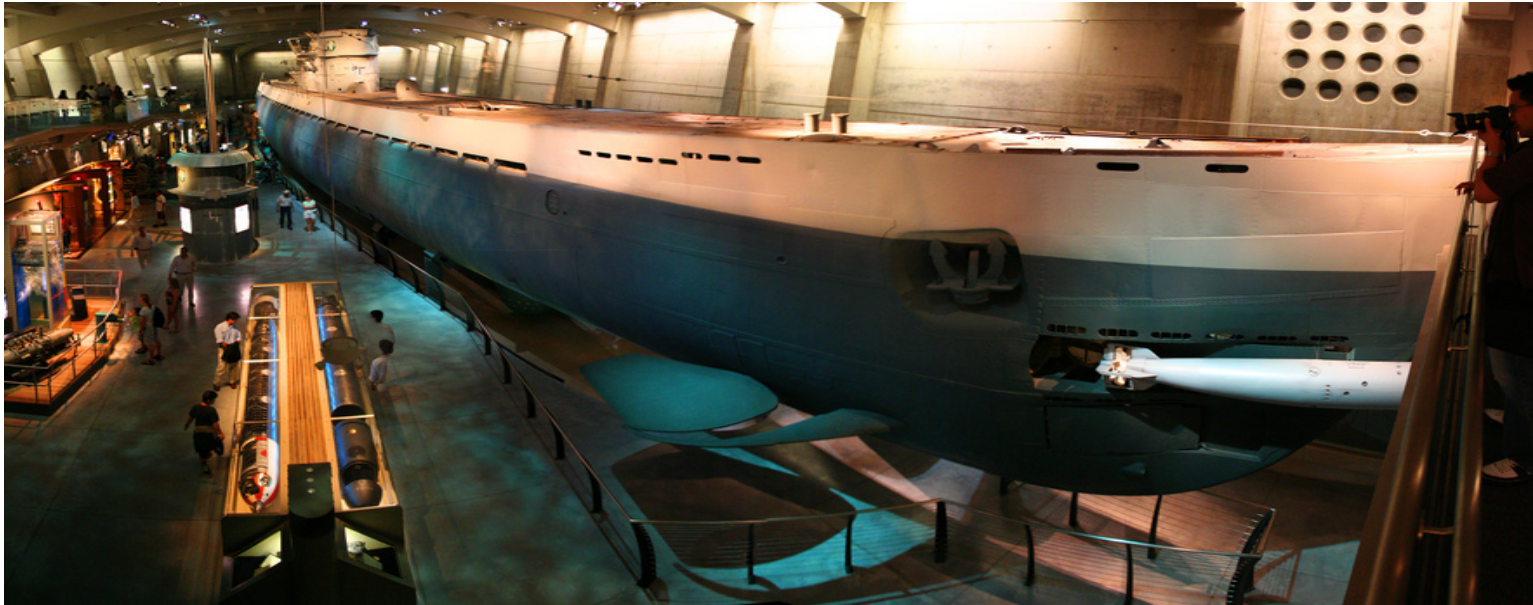

On Display in the Chicago Museum of Science and Industry
now in a shed climate-controlled to inhibit rust.

To get U-505 to Chicago in 1954, passing through the Saint Lawrence Seaway (then not yet fully constructed) and the Great Lakes, required a special dispensation from the Rush-Bagot Treaty of 1818 that still limits U.S. & British (now Canadian) warships on the Great Lakes.

From Sept. 1943 until war's end in May 1945, Allied commanders often knew where U-Boats had been sent. **But where were they?**

Adm. Dönitz demanded regular reports from all his U-Boats.

German radio experts knew a radio signal could betray the sender's position, but only if the signal lasted long enough for the operator of direction-finding apparatus to turn its loop antenna until a "null" was found.

Cf. movies of our agents behind enemy lines sending messages back to London, and Germans in panel trucks with loop antennas on their roofs and operators inside listening to locate the attic from which these clandestine signals emanated.

Skilled operators took at least ten seconds to determine a bearing to the signal.

U-Boat radiomen recorded their ENIGMA-enciphered reports on magnetic wire-recorders (like our old audio tape-recorders), and then played them back sped up so fast that the transmitted radio signal lasted at most 2.5 seconds.

The signal received at U-Boat headquarters in Hamburg or France was wire-recorded and played back at a slower speed to be deciphered by recipients.

Since skilled German operators could not determine a bearing from these very compressed signals, they believed nobody else did it. This belief was wrong.

The Germans did not know about Allied HFDF equipment.

How does *Huff-Duff* work?

Three antennas suffice to gauge direction of radio waves' *Poynting Vector* $\mathbf{E} \times \mathbf{H}$:

Two perpendicular Loop antennas and a Whip antenna mix multiplicatively in ...

Two matched Radio-Frequency amplifiers tuned to the signal's frequency.

Their two outputs drive perpendicular deflection plates/coils of a Cathode-Ray Tube.

Servo-motor drives ganged tuning condensers to scan band of signals' frequencies and stop when a signal exceeds a threshold. That signal's bearing is indicated on the CRT.

(I was employed for part of the summer of 1952 repairing such equipment for the RCN and RCAF.)

“Huff-Duff” display on CRT: (“HFDF” = “High Frequency Direction Finding”)

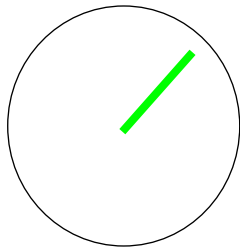

Streak had length proportional to intercepted signal's strength, and pointed to its direction, and persisted slightly longer.

Mathematician Wally Fraser, who had served in a Canadian Corvette, told me in 1956 how HFDF exposed U-Boats' positions whenever they radioed 2.5-sec. compressed reports back to U-Boat HQ. Convoy escorts and shore stations recorded times, bearings and frequencies of signals that resembled U-Boat's reports. Then radio-telephone collaboration among Allied eavesdroppers led to triangulation of the source within a region small enough for search by aircraft or destroyers whose Radar had a range no greater than about 20 mi. then.

Sonobuoys deployed in late 1944:

Microphones dropped onto the ocean by an aircraft wherever a U-Boat was suspected, they broadcast whatever they heard by a precursor of Spread-Spectrum (patented by movie star Hedy Lamarr !) so that noises Axis eavesdroppers would hear sounded like *static*.

Nowadays Spread-Spectrum radio is used also by Cell-Phones both for security and to help share radio spectrum among large numbers of intermittent users.

Germans found out only after the war that ...

- the U-Boats' frequent reports to HQ betrayed their positions to Huff-Duff, and that
- U-Boats moving deep under water were audible to aircraft that had dropped Sonobuoys to detect them, and that
- encrypted messages from U-Boat HQ were often decrypted and decoded by the Allies the same day as they were sent.

The story of Werner H.:

- 1920 Born in Berlin.
- 1934 Joined *Hitler Jugend*, got Nazi indoctrination like “**Democracy is doomed.**”
- 1937-9 Joined German Navy -- Submarines; made Chief Engineer on U-Boat; married.
- 1940 North Atlantic - defective torpedos ran too deep etc.
- 1941 Mediterranean - sortied from southern French ports against British shipping.
- 1942 Caribbean and South Atlantic “vacation cruises” sank mostly American shipping.
- 1943 North Atlantic - equipped with *Zaunkoenig*, *Metox*.:
 - Zaunkoenig* torpedo homed in on propellor noise; foxed by noisy *Foxers*.
 - Metox* super-regenerative receiver detected 1500 cm Radar, not 10 cm.
 - “Apolitical” Werner indifferent to fates of Jews & Slavs; “**I never met one.**”
- 1944 North Atlantic - sortied from Norwegian ports; thwarted by convoy escorts’ vigor.
 - He reviles *only military* conspirators breaking oaths to Hitler in July plot to kill him.
- 1945 U-Boat equipped with *Schnorkel*, *Naxos*:
 - Schnorkel* let U-Boat run on Diesel engines at high speed just under surface.
 - Naxos* sometimes detected 10 cm. Radar, but not 3 cm.
 - Under Halifax harbour; surfaced nightly to recharge batteries, sink a ship, submerge.
 - Surrendered at Argentia, Newfoundland, upon war’s end in May.
 - Credited his survival against 3-to-1 odds to his “**cowardly captain.**”
 - (28,000 of 37,000 Germans in submarines were killed, mostly after 1943; they killed ≈ 40,000 Allied seamen, mostly before 1944.)
 - Werner was interned near Toronto; enjoyed “**best days of my life.**”
- 1947 Repatriated; allowed only menial labor under deNazification laws; divorced.
- 1951-4 Admitted to Tübingen Univ. via a subterfuge; Bachelor’s degree in Mathematics.
- 1956 Helped restore “**shamefully**” captured **U 505** in Chicago museum of Sci. & Tech.
- 1959 Recalling “best days,” emigrated to Toronto.
- 1961 Worked with me at Univ. of Toronto Computing Centre.
- 1967 Commercial computing; remarried; settled; still thinks “**Democracy is doomed.**”
- 1999 Brief speaking part in Public TV’s account of “Hitler’s Lost U-Boat” (U869) which had been believed sunk near Morocco but sank itself accidentally off the New Jersey coast.

Metox and *Naxos* vs. Radar

In late 1942, U-Boats were being ambushed in the Bay of Biscay between their bases in occupied France and their Atlantic assignments. At night, or from low clouds, British aircraft would swoop down, illuminate the sub, and drop bombs. British coastal aircraft and convoy escorts had been fitted with 1.5 m. Radar. U-Boats were soon issued *Metox* radios (named after their French maker) to warn when Radar was in use within 60 miles, well beyond its range. Warned, a U-Boat could submerge, but then went too slow under water to overtake Allied convoys, so it survived but with diminished lethality.

Noise excites oscillations at random, damped out by bias across grid-leak resistor R. But signals at a tuned frequency synchronize with oscillations to be greatly amplified. So, cheap Super-Regenerative receivers are very sensitive but also tricky to adjust.

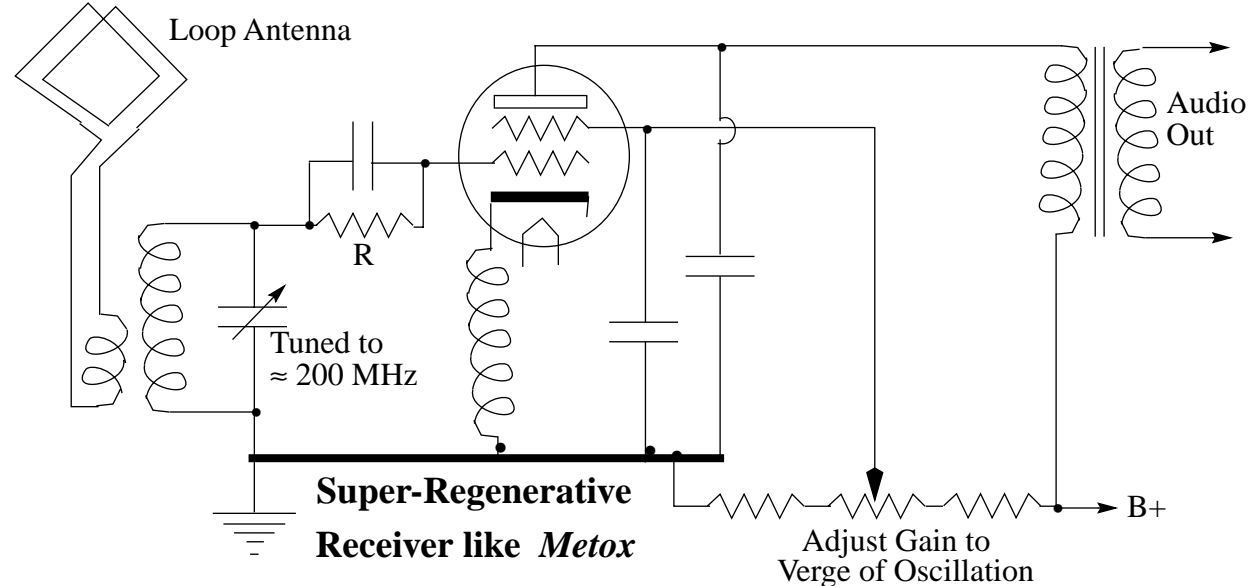

In late 1943 ambushes resumed. First they were attributed to 10 cm. magnetron-powered Radar which Germans discovered in a downed British bomber; but no such signals were detected by German patrols over the Bay of Biscay. A captured RAF flyer let slip that Allies “homed in on” U-Boats which, reasoned the Germans, must radiate something.

Discovering weak radiation emanating from their *Metox* receivers, the Germans figured the British had homed in on it much the way German night-fighter aircraft homed in on 1.5 m. Radar radiated by British bombers over Germany. Now U-Boat captains shared British pilots' dilemmas about whether and when to turn on their electronic equipment.

But the Allies weren't listening to *Metox*. Though bombers attacking Germany got the highest priority for 10 cm. Radar installations, Naval escorts and coastal patrol aircraft received a few also. As more sub-hunters got 10 cm. Radar, more U-Boats succumbed.

Why had Germans searching the Bay of Biscay for 10 cm. Radar failed to find it? First, it was scarce in 1943; secondly, their early *Naxos* Radar-detectors malfunctioned too often. That era's vacuum tubes couldn't amplify 10 cm. (3 GHz) signals until after they had been heterodyned in a fragile point-contact germanium diode of British invention. Early American-made diodes malfunctioned too often too despite British help denied the Germans; modest overloads still burn out point-contact diodes.

By early 1944 *Naxos* detectors for 10 cm. Radar worked well enough to be installed in U-Boats and German night-fighter aircraft. Not long thereafter the Allies deployed 3 cm. Radar which, undetectable by *Naxos*, could pick up new U-Boats' *Schnorkels* while they cruised on their diesel engines barely under water. Sonobuoys picked them up too.

In 1945 Germany launched a U-Boat faster under water than most escort vessels on the surface. And then the war ended. Could this new fast submarine have changed history? Unlikely while the Allies would still ...

- Decrypt orders radioed to U-Boats, and thus ambush them,
- Locate them by Huff-Duff when they radioed their reports back to headquarters,
- Spot their *Schnorkels* on the surface by Radar, detect deep subs by Sonobuoys,
- Attack them with aircraft from small aircraft carriers escorting convoys, and
- Dry up the U-Boats' diesel fuel by bombing German oil refineries.

Submarines were doomed ... until they came out with nuclear engines and quiet propellers.

U-Boat Bases seemed Impregnable



Germans built these U-Boat pens using forced French labor at Lorient on the north coast of the Bay of Biscay. Similar pens were built elsewhere in France, Holland, Norway and Germany. Concrete roofs are several meters thick and surmounted by “Flak Towers” that held 88 mm. guns to discourage aerial attack. Conventional one-ton bombs made little impression on these pens.

British engineer Barnes Wallace (*Wellington* bomber, bouncing bombs used against Ruhr’s dams, ...) designed 5-ton and 10-ton bombs in hard steel cases to penetrate and collapse the pens’ roofs. Cf. ending of movie “Das Boot”.



Ten-ton “Grand Slam” bomb.

5- and 10-ton bombs were so costly that very few were built in 1944-5.

The RAF’s Avro Lancaster was then the only aircraft that could carry a 10-ton bomb and drop it from an altitude sufficiently high that the bomb struck at near supersonic speed to penetrate several yards of dirt and concrete or stone before exploding, collapsing nearby structures.

Such bombs also collapsed tunnels and viaducts, and sank battleships Tirpitz and Lützow. But they did little harm to the U-Boat pens.

Modern versions of this bomb are called “Bunker Busters”.

Willful Destruction of Cities

Annoyed by an ineffectual RAF raid upon Berlin, Hitler redirected Luftwaffe attacks from RAF airfields, which would otherwise have been overwhelmed, to London. Only French fog saved St. Paul's Cathedral from another attack after firestorms had consumed much of central London in Dec. 1940. Later Luftwaffe night attacks upon English cities seemed to justify a vengeful RAF's retaliatory night raids upon German cities despite heavy losses.

US airforce doctrine at first restricted air attacks to military and industrial targets in daylight. But only the most skilled aircrews could find and hit a target smaller than a city; and then the Germans would reconstruct that target promptly unless the area around it had been bombed to damage lines serving communications, transportation, gas, electricity, water and sewage. Thus USAAF and RAF bombers collaborated in 1943 to burn central Hamburg and 40000 souls. Berlin was bombed heavily in 1944-5 ostensibly to draw some German defenders away from the eastern front. In fact, Allies hoped heavy bombing would soon demoralize Germans into quitting. But the Gestapo hanged "traitors" who openly advocated German surrender. Death and destruction continued unabated.

Did Germans deserve punishment for nearly-unanimously supporting Hitler from 1933 to late 1942 ? If so, what do Americans deserve for supporting initially the immoral, illegal and, worst of all, incompetent invasion of Iraq ?

Technically Adept Manpower comes into Critically Short Supply

The British air force was first to experience a shortage of technically talented and trained manpower to operate and service radar sets on the ground and in aircraft. The shortage of such talent led to the use of women as radar operators on the ground, and they turned out to perform their tasks well, better than men on average, even under direct attack by German bombers in 1940.

By the time the British Admiralty realized their warships needed the same kind of talent, it was practically unavailable. A training program set up in the Physics Dept. at the University of Toronto (my *alma mater*) filled the gap; from 1940 to 1942 it sent 93 Canadian men to constitute the majority of radar officers on British warships, and 330 more to operate anti-submarine equipment.

When America entered the war, the U.S. Army and its Air Corps (but not the Navy at first) studied British experience to avoid repeating its mistakes.

The Japanese military never did award enough respect to the technological talent responsible for their weaponry, so their deployed capabilities did not improve much during the war.

In Germany the shortage of technically talented and trained manpower was appreciated too late to remedy even by levies upon conquered peoples and upon inmates of concentration camps. ...

The *Rotterdam Gerät* (Apparatus)

In Feb. 1943, a British bomber shot down over Rotterdam exposed *H2S*, the Allies' 10 cm. Radar, to German *Telefunken* technicians. After a few months' work assembling parts salvaged from other downed bombers, they learned how far their own 50 cm. Radar had fallen behind the Allies'.

By now too many German technicians had been sent to the Russian front and could not be extricated. The only remaining large reservoir of technically adept personnel available to the Germans were Jews held in death-camps. But employing them would run counter to Nazi ideology that disparaged "Jewish Science" and scheduled all Jews for extermination.

Very secretly, Himmler's *S.S.* segregated and compelled technically competent concentration camp prisoners to salvage and analyze electronic equipment from downed Allied aircraft. Barracks for this purpose were built covertly at the *Dachau* camp where, by Dec. 1943, the *S.S.* had assigned prisoner Dr. Hans F. Mayer, formerly director of research for *Siemens & Halske*, to oversee an ultra-high-frequency research lab employing over 100 skilled prisoners.

At most death-camps the *S.S.* were already redirecting sturdy prisoners to slave at hard labor for the *Reich's* profit. In 1944 secret orders reserved technically adept prisoners for another kind of slavery: contributing to German technology.

These orders spared the lives of a number of my friends, none of my relatives.

Proximity-Fuzed Anti-Aircraft Shells: *VERY SECRET*

Americans, British and Canadians (my professors among them) working mostly at Johns Hopkins managed to get duds down to 25%. By late 1943 over a million per month were being produced in U.S. and Canada for \$20 apiece.

Nose of 3.7" – 5" AA shells held a battery-powered radio transmitter-receiver, its vacuum tubes invented at British behest by Toronto company *Rogers*, inventor of battery-less radios for homes. Insulated from heat and shock of firing from gun by layers of plastic and rubber, tiny tubes had elements nicely cantilevered to withstand shell's spin, which forced electrolyte into battery. Near point of closest approach to a targeted aircraft, as determined by *Doppler* effect upon reflected radio pulses, the shell detonated and sprayed shrapnel.

No need to set range nor altitude, allowed rapid-fire: 15 rpm from 5" guns. Sky remained uncluttered by barrage, since smoke-puffs followed only near-missed (within 70 ft.) targets. Wider misses exploded far from the scene when a centrifugal switch detected tumbling.

Proximity fuzes had to be concealed scrupulously from Germans and Japanese who might otherwise have developed and used them against Allied bombers.

Fuzes combatted *Buzz-Bombs* (V-1s) aimed at London and Antwerp; *
Kamikaze suicide bombers over Allies' Pacific fleet; †
Japanese gunners on anti-sub patrol-boats in Sea of Japan;
German soldiers hiding in trenches or behind walls in 1945. ‡

thereby saving innumerable Allied lives. ...

* The V-1 was a cruise missile (1-ton flying bomb) powered after catapult launch by a pulse-jet motor whose fuel cut out over its intended target, mostly London and Antwerp, about 140 miles away. Of 10,000 launched at each city, only 25% got past proximity-fuzed anti-aircraft batteries, a fact British hid by misattributing interceptions to notoriously bold Poles in RAF aircraft.

-----*-----*

Germans looking from Calais to Dover at night could see shells' flashes follow V-1's streaks, but credited hits only to Radar-directed anti-aircraft guns. Proximity fuze never occurred to them. Otherwise they'd have devastated Allied bombers over Germany, where over a million soldiers and 40,000 guns (half Germany's artillery) spit millions of shells skywards to form *flak* barrages.

† The small fraction of Japanese *Kamikaze* suicide bombers that penetrated U.S. naval screens around Okinawa sank or disabled two ships a day. Japanese high command dismissed aviators' reports of proximity fuzes used against them.

‡ Gen. Patton credited the “funny fuze” for appalling casualties German infantry suffered during and after the *Battle of the Bulge* (Ardennes, Dec.'44 - Feb.'45) from barrages that rained shrapnel down from low overhead bursts of proximity-fuzed shells. Their effect was attributed to accurate time-fuzes by German officers lamenting their inability to maintain discipline among troops subjected to such barrages. Still, during WW II's last few months German soldiers inflicted hundreds of thousands of casualties upon Allied soldiers.

So many spies have betrayed the *FBI* and *CIA* recently that we must marvel now that in World War II the Axis powers did not discover (until too late) ...

The Atom Bomb,
That their ciphers were broken,
That every German spy in Britain had been “Turned” or executed,
Huff-Duff located U-Boats whenever they radioed reports to headquarters,
Sonobuoys radioed underwater U-Boats’ propeller noises to aircraft,
Magnetron-powered Radar located schnorkels, ships, planes and cities,
Proximity Fuzes turned near-misses into hits against *V-Is* and *Kamikazes*.

=====

Why should people who like to kill be the only ones who know how?

Much as we deplore War it never stops, so some of us have to think about it. Its main goals are still the extirpation of alleged enemies and the usurpation of conquered resources. The weapons of future wars will probably not be tanks, aircraft carriers, submarines, bombers nor ballistic missiles. Secrecy, stealth, deceit, destruction, infiltration and technology, especially biotechnology, will figure ever larger in future wars. They will grow ever more nasty and costly.

Maybe War would cost us less if we learned how to avert it with ...
sharing instead of greed,
industry instead of indolence,
education instead of ignorance,
science instead of superstition, and
tolerance instead of bigotry.

Alas, these virtues are too much harder to learn and teach than how to kill.

“The trouble with the world is that the foolish are so fervent, and the wise so full of doubt.” Bertrand Russell (1872-1970).

What should you remember most about World War II ?

- Whoever advocates killing the unarmed or disarmed is advocating *Evil*, no matter whether the reason for killing is ...
religious heresy or apostasy or divergence,
ethnic or religious cleansing,
alleged occupation of contested territories,
avoidable “collateral damage” by military action,
death penalty for crimes deemed heinous.
Killing someone can be justified only if *no other way* can be found
to prevent this person from killing.
- You cannot defend your own civil or human rights against attackers.
These attackers will be bullies who attack you whenever
they feel sure you are vulnerable.

Only by defending the rights of others, no matter whether you like
them or not, do you earn their obligation to defend your rights.

Books

In an era of *Google*, *Wikipedia* and *Instant Messaging*, who has time to read books?

Seizing the ENIGMA — the race to break the German U-Boat codes 1939-43 by David Kahn (1998/2001) xii+336 pp., Barnes & Noble

This furnishes almost all the details, padded by paragraphs on the personnels' personalities, but omits mention of HFDF and U-Boats' wire recordings in ch. 17's two-page description of direction-finding. Reading a competent enemy's encrypted signals is a boon unlikely to be enjoyed in future wars.

Battle of Wits — ... Codebreaking in WWII by Stephen Budianski (2000) 436 pp., The Free Press, Simon & Schuster, NY. Historically and mathematically competent.

A World at Arms — a Global History of World War II by Gerhard L. Weinberg (1994) xix+1178 pp., Cambridge Univ. Press

A nearly exhaustive account by a professional historian with some personal experience of the war, this tome includes a Bibliographic Essay of 24 pages and 181 pages of citations, all printed in dense type, plus two dozen rough maps. The rôle of technology in the war receives more attention here than in almost all other histories and memoirs.

The Rise and Fall of Nazi Germany by T.L. Jarman (1956) 368 pp. New York Univ. Press; *Signet* paperback reprint (1961) by the New American Library.

This compact exegesis of the relevant German experiences by an English historian of exceptional perspicacity is still the best, I think. The far more popular and enormously thicker book is ...

The Rise and Fall of the Third Reich — a History of Nazi Germany by Wm. L. Shirer (1960) Simon & Schuster; 30th Anniversary Edn. paperback reprint (1990) 1599 pp., Ballantine Books